

## WELDING AND CUTTING CARRIAGE - KAT® FOR RIGID & SEMI RIGID TRACK

The Gullco KAT® is used throughout the world to automate a wide variety of welding and cutting operations. The KAT® is small and light yet robust with many features which include:



- Tool-less Setup, Adjustment & Operation
- Self-aligning Wheels (Easy Installation)
- Dynamic Dovetail Racking for versatile torch positioning
- Quick clutch mechanism
- OSHA Safety Orange
- Ingress Protection (Sealed Unit) including Conformal Coated Circuit Boards
- Energy Efficient
- Universal Compatibility to all welding power sources and wire feeders
- Torch holder memory for fast torch removal and accurate repositioning after cleaning
- Compatible with all existing rigid track and the new semi rigid track sections

***THE MOST DURABLE, DYNAMIC, AND VERSATILE  
CARRIAGE IN THE INDUSTRY***

# GULLCO

GULLCO.COM





# AUTOMATED WELDING SYSTEM KAT® LT CARRIAGE

## SPECIFICATIONS:

Weight: 17 lb (7.7 kg)

Speed Range: 2.5 - 83.1 cm/min ( 1 - 32.7 IPM)

Racking Weight: 9 lb (4 kg)

Power Requirements: 42 VAC, 115 VAC, 230 VAC  
Models available.

Vertical Capacity: 56 lb (25.4 kg)

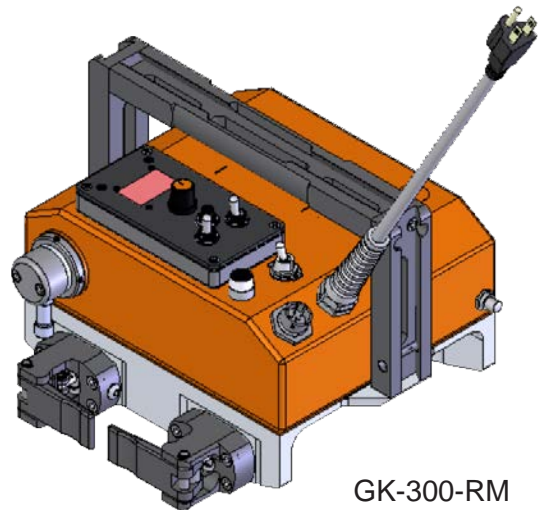

GK-300-RM

## FEATURE RICH ENGINEERED DESIGN

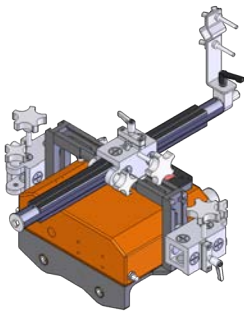

### DYNAMIC RACKING

Using a machined dovetail racking system and locking rack box, torch positioning is versatile and adjustable. The rack box can be positioned anywhere along the racking and torch removal and adjustment is simple.

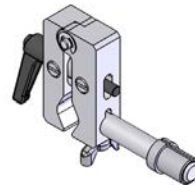

### TORCH HOLDER MEMORY

The torch holder has been designed for quick and easy removal of the torch so that cleaning and accurate repositioning of the welding torch in the optimal position is simple and consistent.

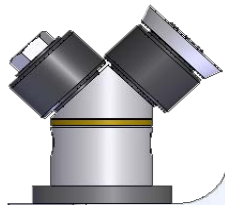

### SELF-ALIGNING WHEELS

Self-aligning wheels means the carriage is mounted to the track correctly and easily every time. This ensures smooth carriage motion and maximizes the life of the track.

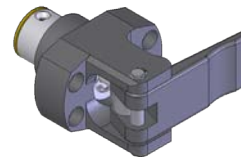

### PADDLE LOCKS

Quick installation paddle locks provide smooth transition of the self-aligning wheels onto the track.

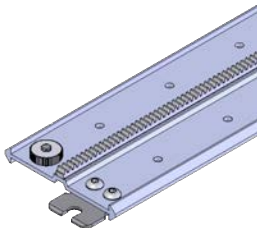

### SEMI RIGID TRACK

Semi rigid track is made from precision extruded aluminum and a securely affixed steel rack. The interchangeable end design enables fast accurate joining of the track sections and provides smooth movement of the carriage along the track in both flat and curved surfaces. Flexibility to a minimum diameter of 24ft (7315.2mm) internal or external.

### MACHINED UNDERCARRIAGE

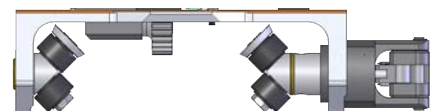

Lightweight design engineered for optimal setup times utilizing the self-aligning wheels and paddle lock technology.

### **GK-L-300 KAT® Rugged Light Weight Carriage Linear Welding Oscillation Combination**

Carriage Speed 1 - 32.7 IPM (2.5 - 83.1 cm/min)  
Heavy duty quick action self-aligning wheels  
combined with two track mounting paddled locks.  
Accurate Carriage speed control by conformal coated  
ingress protected 24 volt Gullco microprocessor.

Maximum load capacity 56 lb (25.4 kg) regardless  
of weld position. With forward/stop/reverse switch,  
high speed return, infinitely variable multi-turn speed  
potentiometer and LED display. Oscillator control  
provides Auto Arc Start , independent dwell at each  
end and center of the 1.5" stroke, infinitely variable 0  
to 5 seconds; oscillation speed potentiometer, speed  
range 8 to 188 cycles per minute (16 to 376 passes  
per minute). Weld oscillator head mounted on  
infinitely variable dovetailed tool-less racking system.

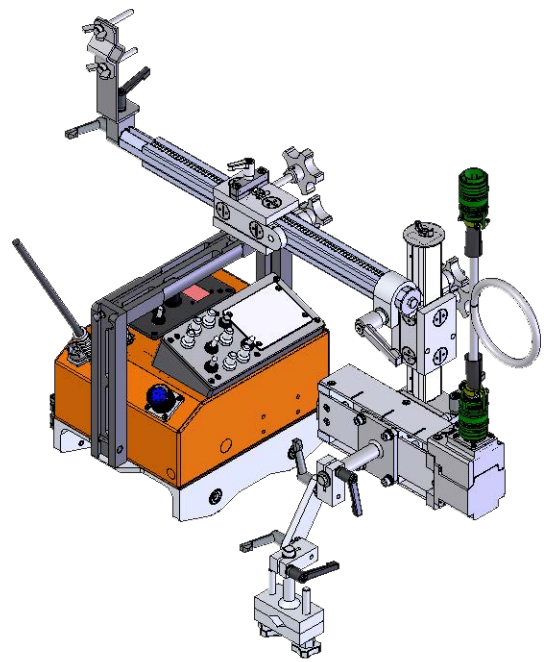

### **GK-R-300 KAT® Rugged Light Weight Carriage Radial Welding Oscillation Combination**

Carriage Speed 1 - 32.7 IPM (2.5 - 83.1 cm/min)  
Heavy duty quick action self-aligning wheels  
combined with two track mounting paddled locks.  
Accurate Carriage speed control by conformal coated  
ingress protected 24 volt Gullco microprocessor.

Maximum load capacity 56 lb (25.4 kg) regardless  
of weld position. With forward/stop/reverse switch,  
high speed return, infinitely variable multi-turn speed  
potentiometer and LED display. Oscillator control  
provides Auto Arc Start , independent dwell at each  
end and center of the 0.8 - 45° oscillation width  
stroke, infinitely variable 0 to 5 seconds; oscillation  
speed potentiometer, speed range 1° - 45° per  
second. Weld oscillator head mounted on infinitely  
variable dovetailed tool-less racking system.

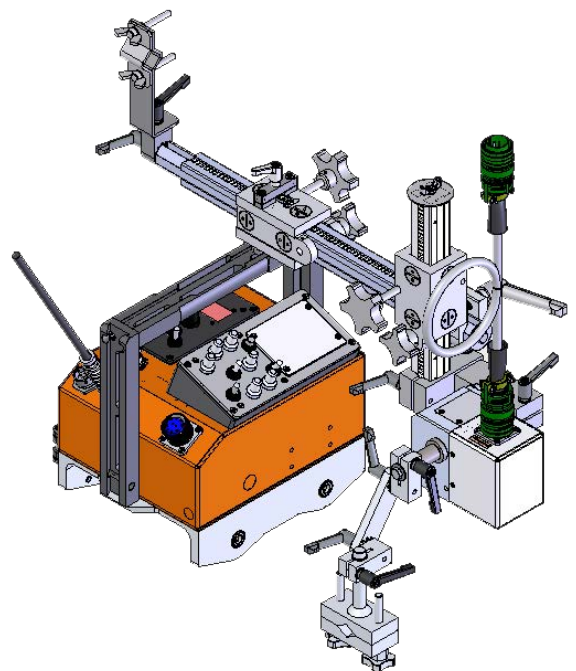



The Gullco Standard Platform (GSP) range of controls have switching for forward / neutral / reverse, run / stop, Manual / Auto & program variable increment/decrement (where applicable) and a rotary encoder for speed control. This micro-processor based, 24 volt DC motor control can be supplied to provide a variety of "optional" functions such as indexing, weld oscillation and auto-weld. The selected "option" function and carriage travel speed/ direction are directed by a single GSP control. This ensures high levels of accuracy, quality and reliability.

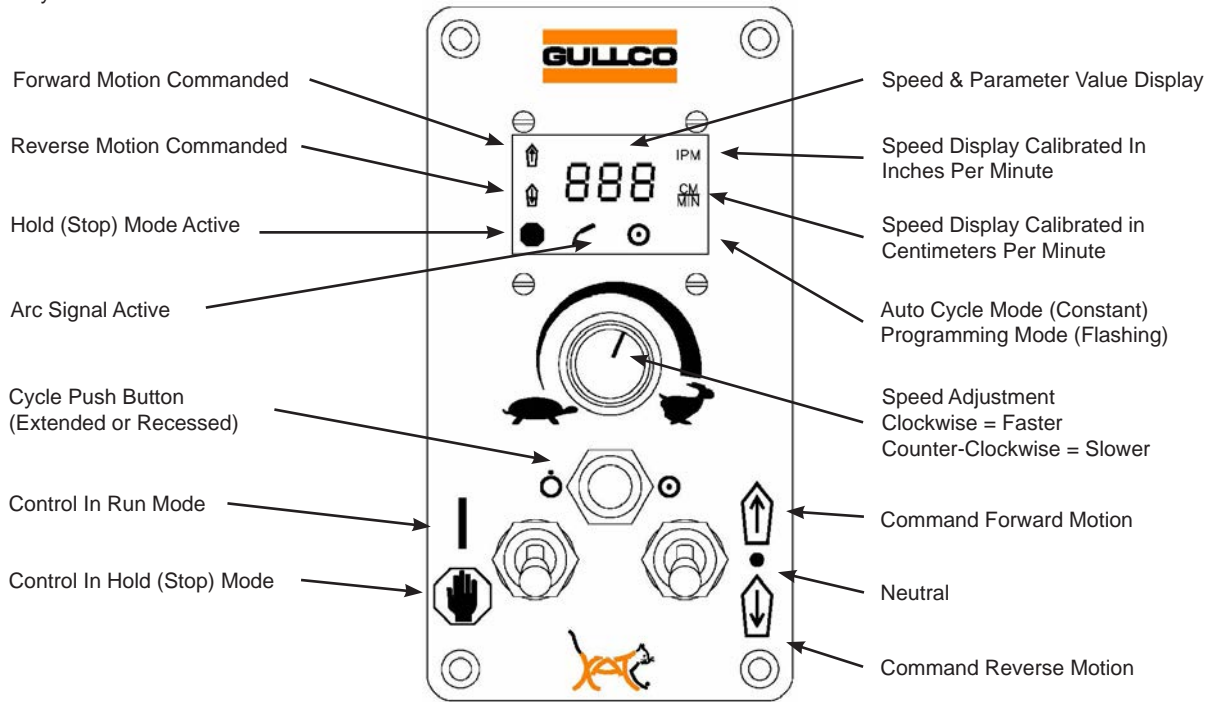

### PART NUMBER CONFIGURATION

Select a option and voltage to configure a KAT® specifically suited to your needs

**GK-**  **-300-**

MODEL OPTIONS	
MODEL	DESCRIPTION
W	Welding Package
AW	Auto-weld
L	Linear Oscillator
R	Radial Oscillator
PC	Plasma Cutting
FC	Flame Cutting

VOLTAGES	
MODEL	INPUT SUPPLY
A	42 VAC
B	115 VAC
C	230 VAC

GULLCO, KAT, KBM, MOGGY, KATBAK & SAM are registered trademarks of Gullco Enterprises Limited

SPECIFICATIONS ARE SUBJECT TO CHANGE WITHOUT NOTICE. ALL DIMENSIONS ARE NOMRAL

Distributed by:

<b>GULLCO</b>		
<b>CANADA - GULLCO INTERNATIONAL LIMITED</b>		
Phone: 905-953-4140	Fax: 905-953-4138	e-mail: sales@gullco.com
<b>U.S.A - GULLCO INTERNATIONAL INC.</b>		
Phone: 440-439-8333	Fax: 440-439-3634	e-mail: ussales@gullco.com
<b>EUROPE - GULLCO INTERNATIONAL (U.K.) LIMITED</b>		
Phone: +44 1257-253579	Fax: +44 1257-254629	e-mail: uksales@gullco.com
<b>AUSTRALIA - GULLCO INTERNATIONAL PTY LIMITED</b>		
Phone: 61 (0)7 3348 5515	Fax: 61 (0)7 3348 5510	e-mail: ausales@gullco.com
<b>INDIA - GULLCO INTERNATIONAL INDIA PVT LIMITED</b>		
Phone: +91-20-2551-1433	Fax: +91-20-2551-1433	e-mail: indsales@gullco.com
<b>CHINA - GULLCO INTERNATIONAL SHANGHAI LIMITED</b>		
Phone: +8621-50460341	Fax: +8621-50463554	e-mail: c.zhang@gullco.com
<b>SINGAPORE - GULLCO INTERNATIONAL LIMITED</b>		
Phone: +65-9385-4468		e-mail: benny.lim@gullco.com
<b>LATIN AMERICA - GULLCO INTERNATIONAL LIMITED</b>		
Phone: 55-11-99485-1336		e-mail: rogerio.macedo@gullco.com
<b>GERMANY - Stuch Schweißtechnik GmbH &amp; Co. KG</b>		
Phone: +49(0)203-729495	Fax: +49(0)203-729496	e-mail: info@stuch-schweisstechnik.de

**GULLCO.COM**

KAT300-17-01