

SIDE BEAM WELDING CARRIAGE



The Gullco variable speed side beam carriages have a load capacity of up to 1000 lbs.

This unit is controlled with a Gullco GSP control with closed loop track feedback forward / stop / reverse switch, infinitely variable 4-turn speed potentiometer, and LED display. Arc start and end of travel limit switches are included.

Gullco Side Beam Carriages are very versatile and can be equipped with a variety of different accessories suitable for a broad range of applications.

IDEAL FOR MOUNTING

- MIG Wire Feeder
- Submerged Arc Head, Wire, Flux
- Seam Tracking System

Generate Accurate and Repeatable High Quality Weld Results

VARIABLE SPEED SIDE BEAM CARRIAGE SYSTEM AVAILABLE FROM 12" TO 36" LONG



Custom Build Your Own "Side Beam" Track

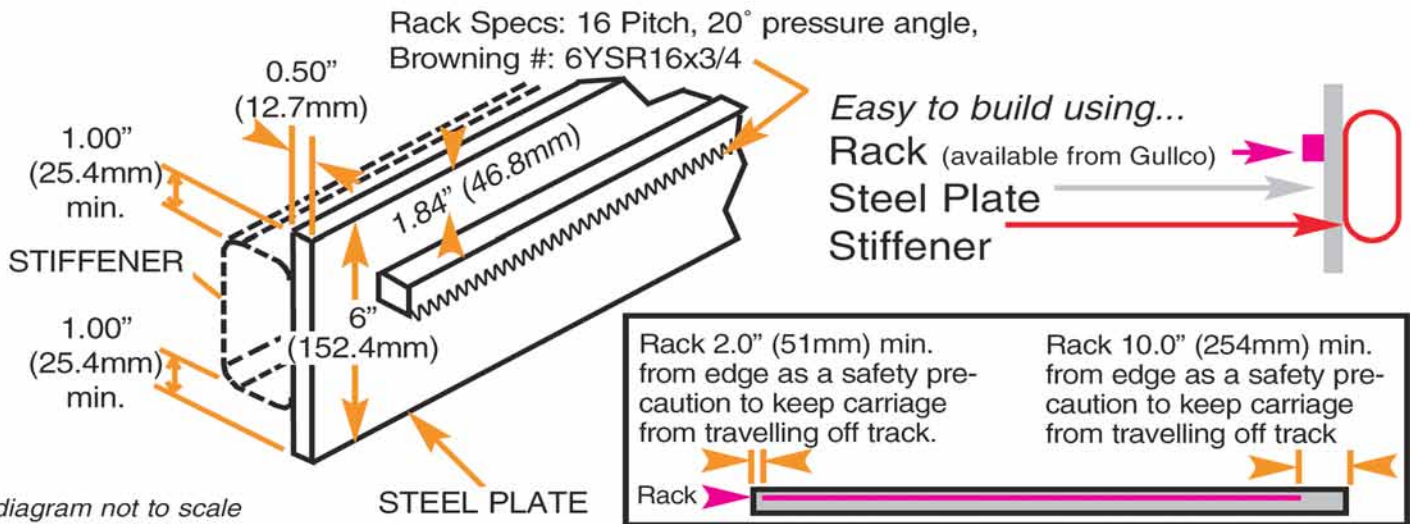

CARRIAGE ACCESSORIES:

SEAM TRACKING AND HEIGHT SENSING ACCESSORIES

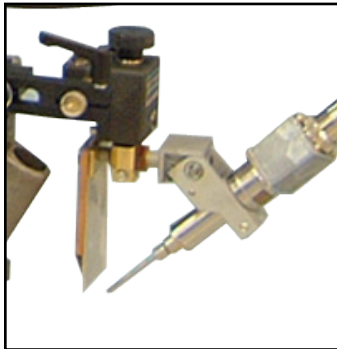

A high precision tracking system that maintains the torch in optimum operating position regardless of variations in the weld seam providing improved quality and efficiency in a wide variety of welding operators.

SIDE BEAM CARRIAGE SUBMERGED ARC ACCESSORIES

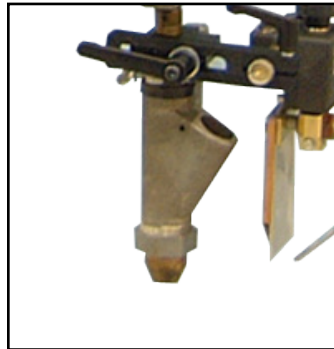

Submerged arc welding system head designed for flux mast mounting. This accessory allows for high quality welds to be produced at a higher productivity rate with minimized weld defects and operator fatigue.

KAT, KBM, MOGGY, KATBAK & SAM are registered trademarks of Gullco Enterprises Limited

SPECIFICATIONS ARE SUBJECT TO CHANGE WITHOUT NOTICE

Distributed by:

GULLCO		
CANADA - GULLCO INTERNATIONAL LIMITED		
Phone: 905-953-4140	Fax: 905-953-4138	e-mail: sales@gullco.com
U.S.A - GULLCO INTERNATIONAL INC.		
Phone: 440-439-8333	Fax: 440-439-3634	e-mail: ussales@gullco.com
EUROPE - GULLCO INTERNATIONAL (U.K.) LIMITED		
Phone: +44 1257-253579	Fax: +44 1257-254629	e-mail: sales@gullco.co.uk
AUSTRALIA - GULLCO INTERNATIONAL PTY LIMITED		
Phone: 61 (0)7 3348 5515	Fax: 61 (0)7 3348 5510	e-mail: ausales@gullco.com
INDIA - GULLCO INTERNATIONAL INDIA PVT LIMITED		
Phone: 91-20-65260382	Fax: 91-20-26836656	e-mail: india.fo@gullco.com
CHINA - GULLCO INTERNATIONAL SHANGHAI LIMITED		
Phone: +8621-50460341	Fax: +8621-50463554	e-mail: gsuntech@sh163.net
SINGAPORE - GULLCO INTERNATIONAL LIMITED		
Phone: +65-9385-4468		e-mail: benny.lim@gullco.com
LATIN AMERICA - GULLCO INTERNATIONAL LIMITED		
Phone: 55-11-9485-1336		e-mail: rogerio.macedo@gullco.com
STUCH GMBH & Co. KG SCWEISSTECHNIK - GERMANY		
Phone: (02 03) 72 94 95	Fax: (02 03) 72 94 96	e-mail: info@stuch-schweisstechnik.de