

## SUBMERGED ARC WELDING CARRIAGE - SAM®



The versatility and reliability of the Gullco MOGGY® trackless travel carriage system and a variety of quality engineered components combine to provide a highly flexible self-contained welding unit. This SAM® unit is designed to produce precision, quality Submerged Arc or MIG welds.

The SAM® Carriage, friction drive heavy-duty welding carriage, with positive chain drive on four (4) rubber tired wheels using a closed loop tack feedback for accurate speed control. The carriage controlled by the Gullco low voltage 24 volt GSP microprocessor pulse width modulation motor control, all mounted in a remote pendant control box attached to 8 ft. (243.84 cm) control cable housing the GSP control providing the forward/stop/reverse switch and infinitely variable 4-turn speed potentiometer. LED display in IPM or cm/min. An interface cable assembly allows the Miller HDC 1500 DX to control the run/stop function of the SAM® Carriage. A manual clutch enables free wheeling. The carriage comes complete with a main mounting mast and handle assembly, mounting arm for one wire reel. All the mounting arms are equipped with quick jaw mast clamp assembly; vertical and horizontal manual 4" x 4" slides (with hardened ground rods with sleeve bearings for ease of adjustment). Control support arm and one (1) set (two[2]) adjustable guide roll arms. For operation on either 42/115/230 volts, single phase, 50/60 Hz AC power supply. Specify voltage when placing order - B = 115 V, C = 230 V.

SAM® Carriage comes in a model for mounting customer's supplied single sub-arc package. Carriage specifications same as Model **GM-02-295**. No welding equipment is supplied.

### *Automate Submerged Arc Welding Applications*

HEAVY DUTY SAM® TRACKLESS WELDING CARRIAGE FOR SUBMERGED ARC AND MIG WELDING

WELDING AND CUTTING



## SPECIFICATIONS

### GM-02-250 SAM® Heavy-Duty Friction Drive Carriage

The carriage specifications are the same as that of the GM-02-295, but provided with 17" x 22" (43.18 x 55.89 cm) aluminum plate providing full flat mounting surface for customer's supplied wire feeder.



**SAM® Submerged Arc Carriage**...Shown set at 45° for beam welding application

**SAM® Heavy-Duty MIG Carriage**...Shown supplied with optional steering mechanism and mast assembly

Special track and wheels

-available upon request.

Power Supply: For operation on either 42/115/230 volts, single phase, 50/60 Hz AC.  
(Specify voltage when placing order - B = 115 V, C = 230 V).

Speed Range: 4 to 66.1 IPM (10 to 168 cm/min)

Weight: 172 lbs (78 kg)

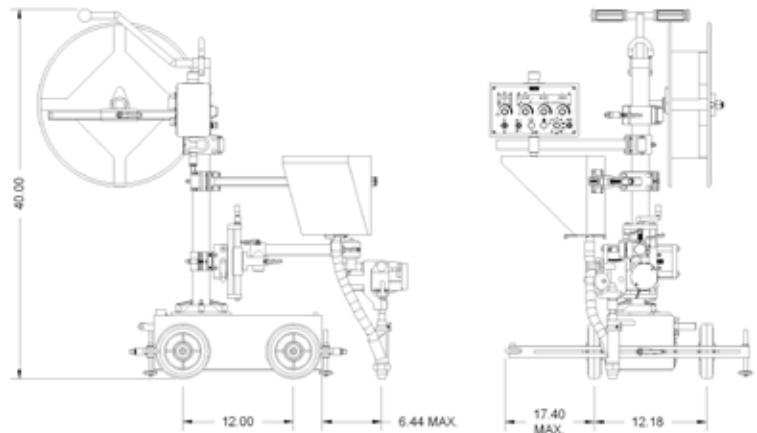

KAT, KBM, MOGGY, KATBAK & SAM are registered trademarks of Gullco Enterprises Limited

Distributed by:

SPECIFICATIONS ARE SUBJECT TO CHANGE WITHOUT NOTICE. ALL DIMENSIONS ARE NOMINAL

**GULLCO.COM**

<b>GULLCO</b>		
<b>CANADA - GULLCO INTERNATIONAL LIMITED</b>		
Phone: 905-953-4140	Fax: 905-953-4138	e-mail: sales@gullco.com
<b>U.S.A - GULLCO INTERNATIONAL INC.</b>		
Phone: 440-439-8333	Fax: 440-439-3834	e-mail: ussales@gullco.com
<b>EUROPE - GULLCO INTERNATIONAL (U.K.) LIMITED</b>		
Phone: +44 1257-253579	Fax: +44 1257-254629	e-mail: uksales@gullco.com
<b>AUSTRALIA - GULLCO INTERNATIONAL PTY LIMITED</b>		
Phone: 61 (0)7 3348 5515	Fax: 61 (0)7 3348 5510	e-mail: ausales@gullco.com
<b>INDIA - GULLCO INTERNATIONAL INDIA PVT LIMITED</b>		
Phone: +91-20-2551-1433	Fax: +91-20-2551-1433	e-mail: indsales@gullco.com
<b>CHINA - GULLCO INTERNATIONAL SHANGHAI LIMITED</b>		
Phone: +8621-50460341	Fax: +8621-50463554	e-mail: c.zhang@gullco.com
<b>SINGAPORE - GULLCO INTERNATIONAL LIMITED</b>		
Phone: +65-9385-4468		e-mail: benny.lim@gullco.com
<b>LATIN AMERICA - GULLCO INTERNATIONAL LIMITED</b>		
Phone: 55-11-99485-1336		e-mail: rogerio.macedo@gullco.com
<b>Stuch GmbH &amp; Co. KG Schweisstechnik - GERMANY</b>		
Phone: (02 03) 72 94 95	Fax: (02 03) 72 94 96	e-mail: info@stuch-schweisstechnik.de