

ORBITAL WELDING CARRIAGE - PIPE KAT® - RIGID TRACK



Carriage Features and Benefits Include:

- Linear or Radial Oscillation
- Remote Voltage Adjustment
- Motorized Width Adjustment
- High Deposition Rate
- Simple Setup
- Easy to Use Controls
- Gas or Water Cooled Models
- Upto 2.5" (6.35 cm) Oscillation Width

PK-500-LG/RG - GAS/AIR COOLED

PK-500-LW/RW - WATER COOLED



Self Contained Orbital Welding System

AUTOMATE AND IMPROVE PIPE WELDING AND ORBITAL WELDING APPLICATIONS





SPECIFICATIONS:

Carriage Weight: 48 lbs (21 kg)

Control Box Weight: 30 lbs (13.6 kg)

Power Requirements: 42, VAC, 115 VAC, 230 VAC
Models available. Power consumption = 400 watts

Carriage Travel Speed: 1.35" - 44.2" (3.42 cm - 112.27 cm) Per Minute

Torch Adjustment: +/- 10°

Oscillation Speed: 0.5" - 140" (1 cm - 355.6 cm) Per Minute

Dwell Times: 0 to 9.9 seconds

Manual Slide Adjustment: 3" (7.62 cm) Vertical

Motorized Torch Adjustment: 2" (5.08 cm) Vertical

Oscillation Width Adjustment: 4" (10.16 cm) total slide adjustment. Max. oscillation width of 2.5" (6.35 cm)

Welding Spool Size: 8"/10 lbs (20.3 cm/4.5 kg)

Operating Temperatures: 0 to 60°C (32 - 140°F)

Wire Feeder Drive Rolls: 0.8 mm to 1.6 mm V-groove wheels, 1.0 mm to 2.0 mm V-groove knurled wheels (1.0/1.2 mm V-groove knurled comes standard, see chart on reverse for available options)

Carriage Umbilical: 25 ft. (7.6 m) in length and protected by a 500°C (932°F) rated cover. Contains torch power cable, shielding gas hose, carriage power cable, arc start cable, and water hoses if equipped

Compatible Welding Processes: All standard CV & CC processes, MIG, TIG, Pulse

Comes with Pipe KAT® Waterproof Carrying Case made by Pelican

The Pipe KAT® is a pipe welding carriage designed for orbital welding. It is an electrically powered track guided carriage that operates in the forward or reverse directions at precisely controlled speeds. The carriage operates on a track band made of durable aluminum extrusion by engaging the track with self-aligning wheels and a rack and pinion drive. This wheel assembly uses a lever to engage that track making it very quick and simple to install the carriage.

The Pipe KAT® is a fully integrated welding system which comes with a wire feeder and wire spool holder. Driven by a 24 VDC motor which feeds wire to the welding torch at precisely controlled speeds. The wire spool holder accepts standard 8"/10 lbs (20.3 cm/4.5 kg) spools.

A remote control pendant is provided to allow adjustment of the critical application parameters during the welding process including, oscillation width, speed, dwells, wire feed speed and voltage adjustment.

CARRIAGE ACCESSORIES

CARRIAGE UMBILICAL

25ft (7.6 m)
Carriage Umbilical
Extension Assembly

PK-500-163-G
PK-500-163-N
PK-500-163-W

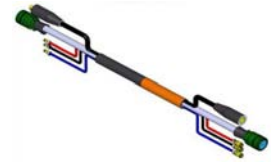

WATER COOLER POWER INTERFACE KIT

Interface allows control to automatically activate / deactivate water cooler during auto-cycle. Toggle switch included for manual override.

PK-200-216-A 42V
PK-200-216-B 115V
PK-200-216-C 230V



FLOW SWITCH KIT

Flow switch is used to monitor coolant flow to welding torch.

PK-500-177

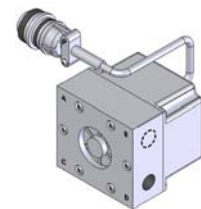

PENDANT EXTENSION CABLE

15 ft (4.6 m) Extension Cable.

PK-200-368



CARRIAGE CONTROL LAYOUT

REMOTE HAND PENDANT

- CARRIAGE WELD SPEED TRIM OVERRIDE
- WELDING VOLTAGE CONTROL
- WIRE FEED JOG
- WIRE FEED SPEED TRIM OVVERRIDE
- CARRIAGE JOG
- WELD ENABLED/DISABLED
- OSCILLATION WIDTH ADJUSTMENT
- TORCH SLIDE JOG
- EMERGENCY STOP
- OSCILLATOR CENTER POSITIONER ADJUSTMENT
- RED & GREEN L.E.D.s
- AUTO CYCLE START PUSH BUTTON
- AUTO CYCLE STOP PUSH BUTTON

CARRIAGE CONTROL

The Remote pendant (left) is used in conjunction with the main control (right) to provide adjustment during setup, initiate the weld cycle, provide fine adjustment during welding, and to stop the weld cycle.

The remote pendant is supplied with a 35ft communication cable that connects to the right side panel of the PIPE KAT® Main Control.

PIPE BAND ORDERING INFORMATION

PB-500- -

Pipe Outside Diameter (inches)
(2 Decimal Places)

Stand-off Height (inches)
Standard = 1.75" (4.45 cm)
up to 6.00" (15.24 cm)
(2 Decimal Places)

EXAMPLE 1:

If the Pipe Outside Diameter (O.D) is 22.357" with a stand-off of 3.5" the part number will be: **PB-500-22.38-3.50**

EXAMPLE 2:

If the Pipe O.D is 24" with a standard stand-off the part number will be: **PB-500-24.00-1.75**

NOTE:

- Stand-off heights over 1.75" (4.45 cm) require spacers. Min. spacer height of 0.50" (1.27 cm)
- All stand-offs are adjustable to +/- 0.157" (4 mm) using the 5 mm allen tool
- Min. \varnothing Track Datum = 17.5" (44.45 cm) [\varnothing Track Datum = \varnothing pipe + (2 x Stand-off Height)]
- Max. \varnothing Track Datum = 60" (152.4 cm) [Consult Factory For Larger Dimensions]

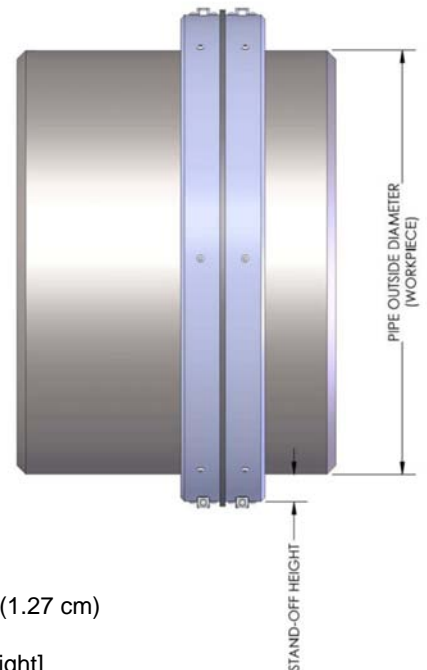

Quick Installation Track Band:

The hinged design of the Pipe KAT® track band makes installation simple and quick.

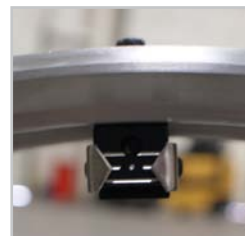

Adjustable Track Mounting Pads:

The Pipe KAT® band comes with stand off pads which allow for +/- 0.157" (4 mm) of adjustment.

PK-500-LG/RG

For use with gas/air cooled welding torch necks and consumables. Additional items are required.

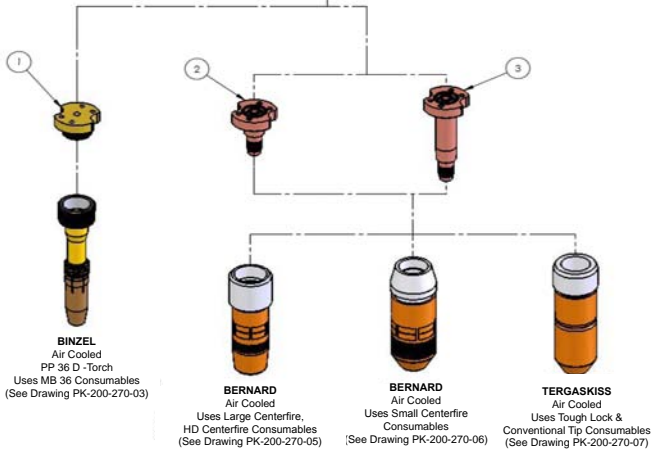

PK-500-LW/RW

For use with water cooled welding torch necks and consumables. Additional items are required.

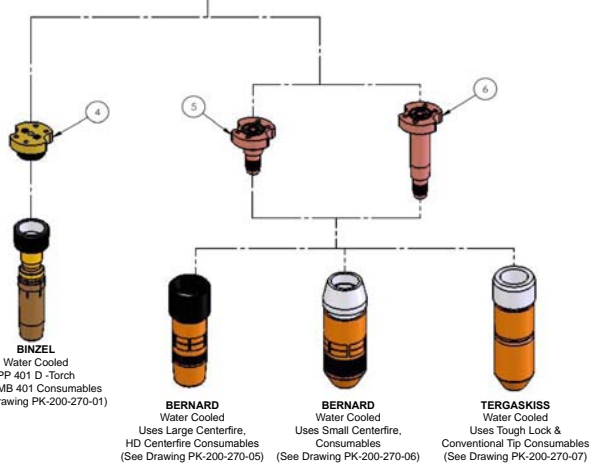

WIRE FEEDER ROLL ORDERING SPECIFICATIONS



PART #	DESCRIPTION	QTY.
PK-200-035-10	Feed Roll V-groove 0.8 mm + 1.0 mm	2
PK-200-035-12	Feed Roll V-Groove 1.0 mm + 1.2 mm	2
PK-200-035-16	Feed Roll V-Groove 1.2 mm + 1.6 mm	2
PK-200-035-12-K	Feed Roll V-Groove 1.0 mm + 1.2 mm Knurled	2
PK-200-035-14-K	Feed Roll V-Groove 1.2 mm + 1.4 mm Knurled	2
PK-200-035-20-K	Feed Roll V-Groove 1.6 mm + 2.0 mm Knurled	2

*The Pipe KAT® has a selection of feeder rolls available for different requirements. The Pipe KAT® comes standard with PK-200-035-12

PIPE KAT® PART NUMBER CONFIGURATION

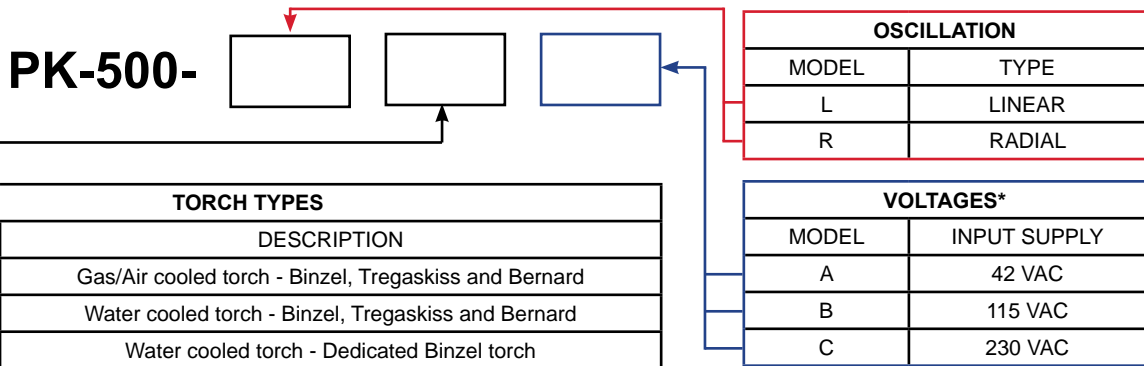

* All above voltage supplies are single phase, 50/60 hz, 400 watts

KAT, KBM, MOGGY, KATBAK & SAM are registered trademarks of Gullco Enterprises Limited

SPECIFICATIONS ARE SUBJECT TO CHANGE WITHOUT NOTICE. ALL DIMENSIONS ARE NOMINAL

Distributed by:

GULLCO

CANADA - GULLCO INTERNATIONAL LIMITED
Phone: 905-953-4140 Fax: 905-953-4138 e-mail: sales@gullco.com

U.S.A - GULLCO INTERNATIONAL INC.
Phone: 440-439-8333 Fax: 440-439-3634 e-mail: ussales@gullco.com

EUROPE - GULLCO INTERNATIONAL (U.K.) LIMITED
Phone: +44 1257-253579 Fax: +44 1257-254629 e-mail: uksales@gullco.com

AUSTRALIA - GULLCO INTERNATIONAL PTY LIMITED
Phone: 61 (0)7 3348 5515 Fax: 61 (0)7 3348 5510 e-mail: ausales@gullco.com

INDIA - GULLCO INTERNATIONAL INDIA PVT LIMITED
Phone: 91-20-6526-0382 Fax: 91-20-2683-6656 e-mail: indsales@gullco.com

CHINA - GULLCO INTERNATIONAL SHANGHAI LIMITED
Phone: +8621-50460341 Fax: +8621-50463554 e-mail: c.zhang@gullco.com

SINGAPORE - GULLCO INTERNATIONAL LIMITED
Phone: +65-9385-4468 e-mail: benny.lim@gullco.com

LATIN AMERICA - GULLCO INTERNATIONAL LIMITED
Phone: 55-11-99485-1336 e-mail: rogerio.macedo@gullco.com

Stuch GmbH & Co. KG Schweisstechnik - GERMANY
Phone: (02 03) 72 94 95 Fax: (02 03) 72 94 96 e-mail: info@stuch-schweisstechnik.de