

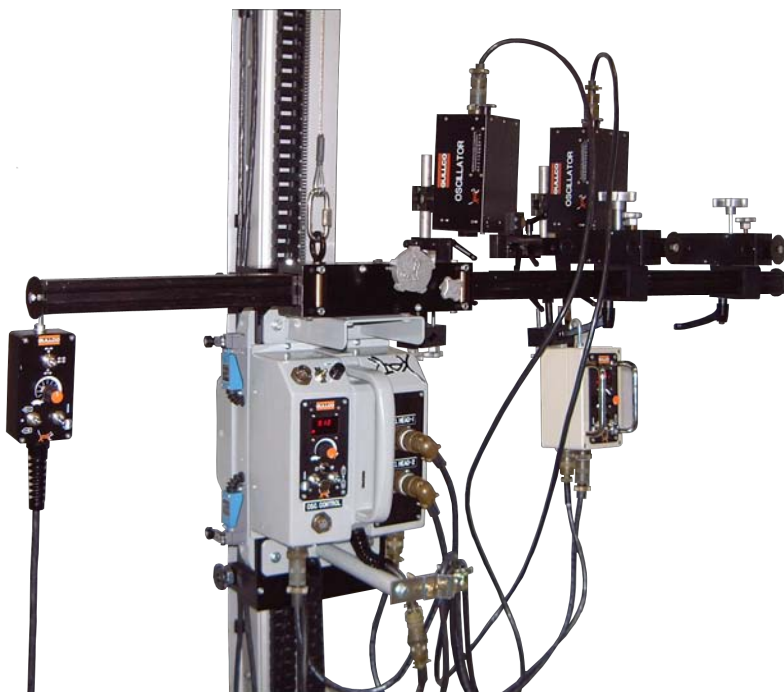

OVERLAY WELDING GANTRY SYSTEM FOR ALL POSITIONS



The Welding Overlay System is designed to operate in all positions. Ideal for use on boiler tube walls, cladding boiler tube walls prior to installation in the boiler, pressure vessel tanks and other applications where overlay repair is required.

The overlay system allows for precise control of the travel speed which allows the operator to achieve clean consistent weld overlay patterns.

The entire system is made up of existing Gullco products and can be easily disassembled into various smaller components for transporting or maneuvering through tighter openings.

Gullco's team of in-house engineers can customize the system to meet specific application requirements and this is used commonly for unique circumferences or wall applications.

The design of the overlay system is made to optimize time with a quick track mounting system which allows for easy alignment with the work piece.

Precise remote control of the overlay system ensures consistent weld quality

MOUNTS EASILY TO AUTOMATE OVERLAY AND CLADDING APPLICATIONS

WELDING AND CUTTING



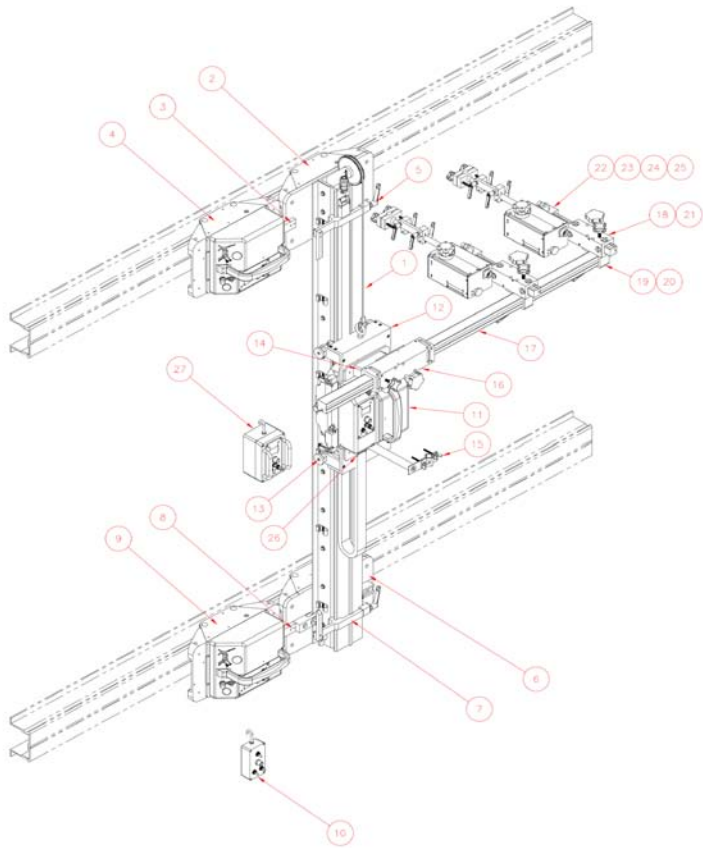

Item	Part Number	Description	Quantity
1	GS-474-024	VERTICAL TRACK ASSEMBLY	1
2	GS-474-013	UPPER IDLER CARRIAGE ASSEMBLY	1
3	GS-441-016	UPPER TOWING LINK	1
4	GS-474-035	UPPER KAT CARRIAGE ASSEMBLY	1
5	GS-474-047	MODIFIED TRACK STOP ASSEMBLY	1
6	GS-441-017	LOWER IDLER CARRIAGE ASSEMBLY	1
7	GK-191-P-061	RIGID TRACK STOP ASSEMBLY	1
8	GS-441-015	LOWER TOWING LINK	1
9	GS-474-030	LOWER KAT CARRIAGE ASSEMBLY	1
10	GS-441-021	REMOTE FOR UPPER & LOWER CARRIAGES	1
11	GS-474-055	VERTICAL KAT CARRIAGE ASSEMBLY (12-27)	1
12	GS-474-060	FRONT EXTENSION ASSEMBLY	1
13	GS-474-061	REAR EXTENSION ASSEMBLY	1
14	GK-190-066	RACK BOX RISER ASSEMBLY	1
15	GK-181-027	CABLE SUPPORT ASSEMBLY	1
16	GB-413-030	1 - 1/2" HEAVY DUTY RACK BOX	1
17	GS-474-070	1 - 1/2" RACK ARM X 48" LONG	1
18	GK-171-650	1 - 1/8" RACK BOX	2
19	GK-190-236	1 - 1/2" RACK ARM SQUARE CLAMP	2
20	GK-153-004	3/8 - 16 UNC FEMALE HAND LEVER	2
21	GK-171-047-1	1 - 1/8" RACK ARM x 12" LONG	2
22	GS-474-100	OSCILLATOR HEAD	2
23	GK-197-0-101	OSCILLATOR HEAD SWIVEL BRACKET	2
24	GK-197-0-102	BRONZE SWIVEL CLAMP ASSEMBLY	2
25	GK-171-112	ADAPTER BLOCK ASSEMBLY	2
26	GS-474-046	CABLE TRACK CLIP	1
27	GS-474-049	VERTICAL KAT REMOTE	1



OPTIONAL PRECISION COMPOUND SLIDES AVAILABLE



KAT, KBM, MOGGY, KATBAK & SAM are registered trademarks of Gullco Enterprises Limited

Distributed by:

SPECIFICATIONS ARE SUBJECT TO CHANGE WITHOUT NOTICE. ALL DIMENSIONS ARE NOMINAL

GULLCO

CANADA - GULLCO INTERNATIONAL LIMITED

Phone: 905-953-4140 Fax: 905-953-4138 e-mail: sales@gullco.com

U.S.A - GULLCO INTERNATIONAL INC.

Phone: 440-439-8333 Fax: 440-439-3634 e-mail: ussales@gullco.com

EUROPE - GULLCO INTERNATIONAL (U.K.) LIMITED

Phone: +44 1257-253579 Fax: +44 1257-254629 e-mail: uksales@gullco.com

AUSTRALIA - GULLCO INTERNATIONAL PTY LIMITED

Phone: 61 (0)7 3348 5515 Fax: 61 (0)7 3348 5510 e-mail: ausales@gullco.com

INDIA - GULLCO INTERNATIONAL INDIA PVT LIMITED

Phone: 91-20-6526-0382 Fax: 91-20-2683-6656 e-mail: indsales@gullco.com

CHINA - GULLCO INTERNATIONAL SHANGHAI LIMITED

Phone: +8621-50460341 Fax: +8621-50463554 e-mail: c.zhang@gullco.com

SINGAPORE - GULLCO INTERNATIONAL LIMITED

Phone: +65-9385-4468 e-mail: benny.lim@gullco.com

LATIN AMERICA - GULLCO INTERNATIONAL LIMITED

Phone: 55-11-99485-1336 e-mail: rogerio.macedo@gullco.com

Stuch GmbH & Co. KG Schweisstechnik - GERMANY

Phone: (02 03) 72 94 95 Fax: (02 03) 72 94 96 e-mail: info@stuch-schweisstechnik.de