

“low cost, highly efficient automation of out-of-position fillet, lap and butt welding applications”

This Gullco Magnetic Moggy® is essentially the same as the Standard Moggy described inside this folder except it has a magnetic base and heavy duty urethane 0.875” (22.23 mm) wide wheels for continuous travel in the horizontal and vertical position. Two Models are available:

Magnetic MODEL GM-03-350 (Standard Model GM-03-050) Moggy Carriage with control for **continuous travel**, and with forward/stop/reverse switch, wire feed start on/off switch, travel speed potentiometer, auto wire feed start with delay carriage start, travel speed displayed in LED window, wire feed connector with 15ft. (4572mm) control cable.

Magnetic MODEL GM-03-300 (Standard Model GM-03-100) Moggy Carriage with control for **continuous or stitch welding**, and with a control that uses a Gullco micro-processor to provide accurate repeatability regardless of travel speeds for weld distance on and weld distance off. It has a forward/stop/reverse switch, wire feed start on/off switch, travel speed potentiometer, auto wire feed start with delay carriage start, wire feed connector with 15 ft. (4572mm) control cable. All functions displayed in LED window.

GM-03-320 - Magnetic Retro Fit Kit is available to upgrade your Standard GM-03-050 & GM-03-100 Moggy to a Magnetic Moggy.

Adjustable guide roll assemblies ensure accurate gun positioning while the Moggy carriage moves at precisely controlled speeds in forward/reverse direction. (see inside for details on the MOGGY®)



GULLCO

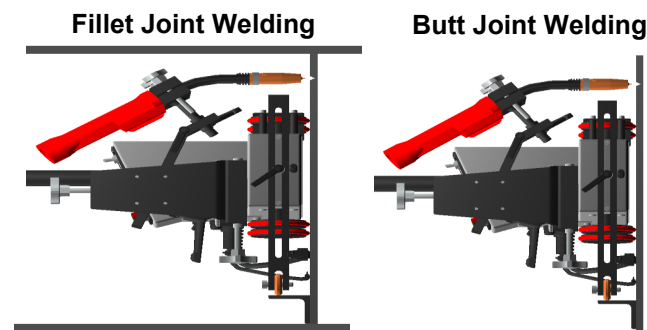

EFFICIENT...EFFECTIVE...VERSATILE
The Gullco magnetic moggy is highly versatile and is ideally suited to a wide variety of welding applications, particularly in Tee fillet welding where there is not enough room for the carriage to run on the horizontal plate.

MOGGY & MAGNETIC MOGGY FILLET WELDING CARRIAGE

STANDARD MOGGY CARRIAGE



MAGNETIC MOGGY CARRIAGE

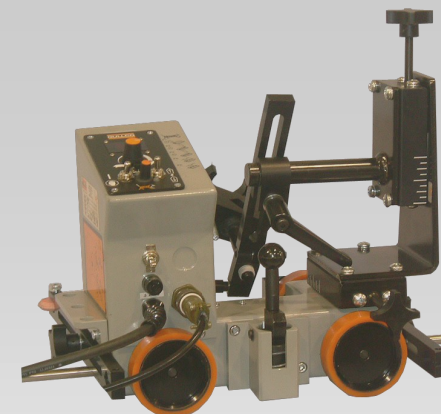

Carriage Model Options:

- Single or Dual Torch Models
- Magnetic or Non Magnetic Base
- Continuous or Stitch Welding Models

Additional carriage options are available:

- Weld Oscillator Head
- Lap Weld Guide Wheels
- Inside Radius Attachment
- Cutting Torch Attachment
- V-Groove Track



KAT, MOGGY, KATBAK & SAM are registered trademarks of Gullco Enterprises

SPECIFICATIONS ARE SUBJECT TO CHANGE WITHOUT NOTICE

Distributed by:

GULLCO		
GULLCO INTERNATIONAL LIMITED - CANADA		
Phone: 905-953-4140	Fax: 905-953-4138	e-mail: sales@gullco.com
GULLCO INTERNATIONAL INC. - U.S.A		
Phone: 440-439-8333	Fax: 440-439-3634	e-mail: ussales@gullco.com
GULLCO INTERNATIONAL (U.K.) LIMITED- EUROPE		
Phone: +44 1257-253579	Fax: +44 1257-254629	e-mail: sales@gullco.co.uk
GULLCO INTERNATIONAL PTY LIMITED - AUSTRALIA		
Phone: 61 (0) 7 5439-0701	Fax: 61 (0) 7 5439-0704	e-mail: ausales@gullco.com
GULLCO INTERNATIONAL INDIA PVT LIMITED - INDIA		
Phone: 91-20-65260382	Fax: 91-20-26836656	e-mail: india.lo@gullco.com
GULLCO INTERNATIONAL SHANGHAI LIMITED- CHINA		
Phone: +8621-50460341	Fax: +8621-50463554	e-mail: gsuntech@sh163.net
GULLCO INTERNATIONAL LIMITED- LATIN AMERICA		
Phone: 55-11-9485-1336	e-mail: rogerio.macedo@gullco.com	
STUCH GMBH & Co. KG SCWEISSTECHNIK - GERMANY		
Phone: (02 03) 72 94 95	Fax: (02 03) 72 94 96	e-mail: info@stuch-schweisstechnik.de

GULLCO

WELDING AND CUTTING AUTOMATION

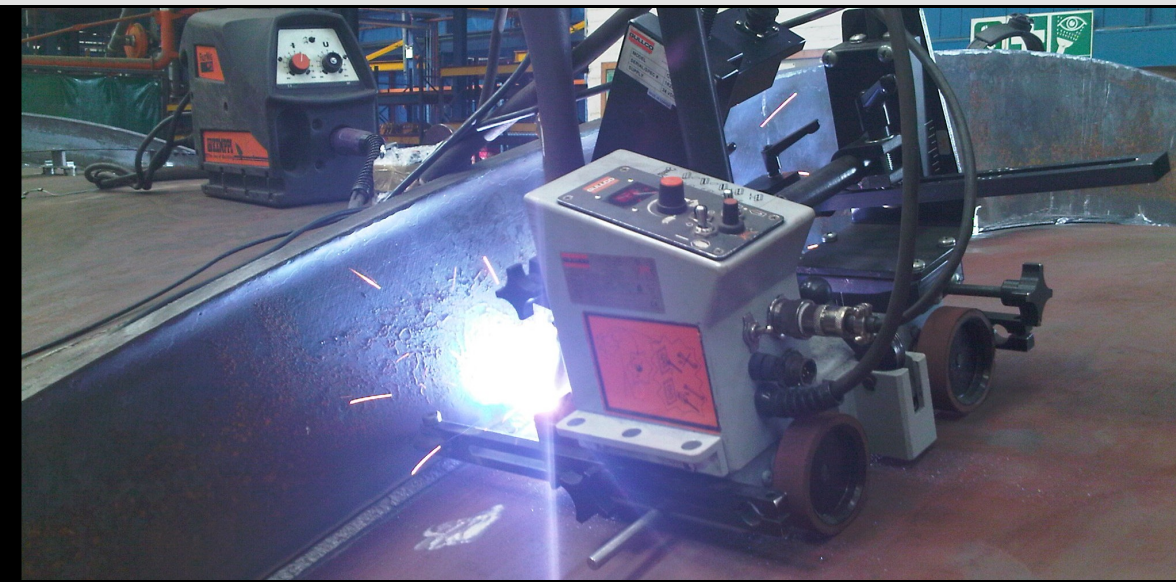

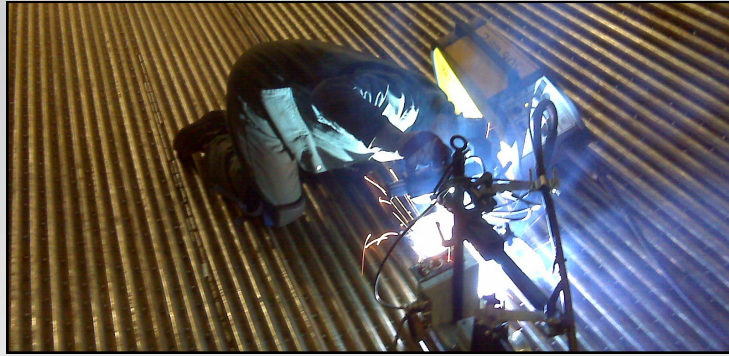

It is a lightweight, portable, four wheel friction drive travel carriage that can be used with or without track to automate welding operations. A speed potentiometer provides infinite speed selection within the speed range. The unit comes complete with adjustable guide rolls, travel limit switch assembly, vertical and horizontal slides providing 1 3/4" (44.4mm) adjustment and a semi-automatic gun holder. It is designed to run on a horizontal path against a vertical surface or a vertical path against a horizontal surface (Magnetic Moggy) to perform a fillet weld.

The Standard Moggy can be adapted for use on standard 6" (152.4mm) v-groove track by reversing the wheel assemblies. Safety is assured by using Gullco low voltage 24 volt DC highly advanced control power supply system that is available in 3 line voltage inputs ... 42, 110 and 230 volt AC 50/60 Hz.

Please specify line voltage when ordering.
(Magnetic Moggy® details on back)

Standard MODEL GM-03-050

(Magnetic Model GM-03-350)
Moggy Carriage with control for **continuous travel**, and with forward/stop/reverse switch, wire feed start on/off switch, travel speed potentiometer, auto wire feed start with delay carriage start, travel speed displayed in LED window, wire feed connector with 15 ft. (4572mm) control cable.

Standard MODEL GM-03-100 (Magnetic Model GM-03-300) Moggy Carriage with control for continuous or stitch welding, and with a control that uses a Gullco microprocessor to provide accurate repeatability regardless of travel speeds for weld distance on and weld distance off. It has a forward/stop/reverse switch, wire feed start on/off switch, travel speed potentiometer, auto wire feed start with delay carriage start, wire feed connector with 15 ft. (4572mm) control cable. All functions displayed in LED window.

The Gullco Moggy is a highly reliable, versatile heavy duty travel carriage which is ideal for a wide range of applications

The Moggy can be adapted to automate and reduce welding and set up costs in a broad range of applications. Some typical configurations are shown below

Lap Joint Welding

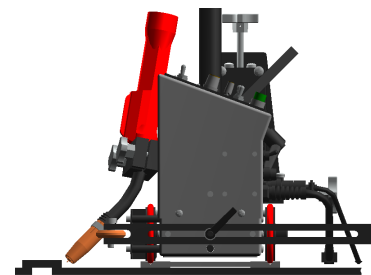

The Moggy is performing a lap joint weld. It is guided by Industry Standard 6" (152.4mm) v-groove Track running parallel to the joint.

Fillet Joint Welding

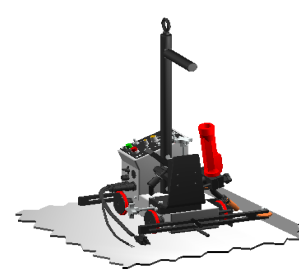

The Moggy performing a fillet weld using a template, guide or fence positioned parallel to the workpiece. The actual workpiece is often used as the guide.

Dual Gun Welding

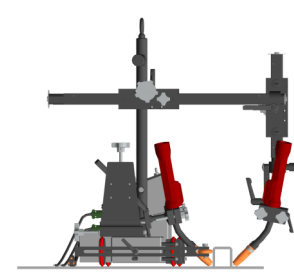

Dual gun holder assembly mounted on the Moggy enables positioning of 2 guns and simultaneous activation of two wire feed signals. Moggy is guided by the workpiece.

Butt Joint Welding

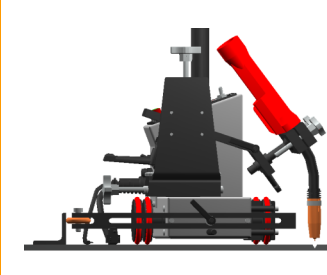

The Moggy is ideal for butt joint welding. Here the Moggy is using a fence to guide it accurately along the desired path. Standard v-groove track can also be used.

Joint Tracking

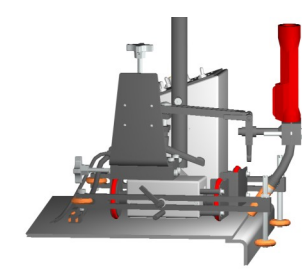

Adjustable height guide roller assemblies are available to track joints with a vertical member higher or lower than the set height of guide roller wheels.

Radial Oscillator

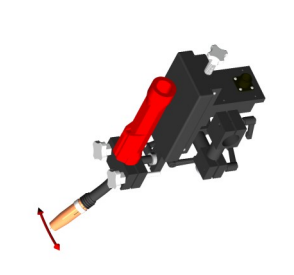

Replaces the standard gun holder assembly in order to weave the gun across the joint while the Moggy provides the weld travel motion.

Precise Torch Alignment To The Seam

Adjustable guide rolls mounted on the front or back of the carriage monitor the slightest seam variations following straight or curved surfaces...maintaining optimum torch positioning.

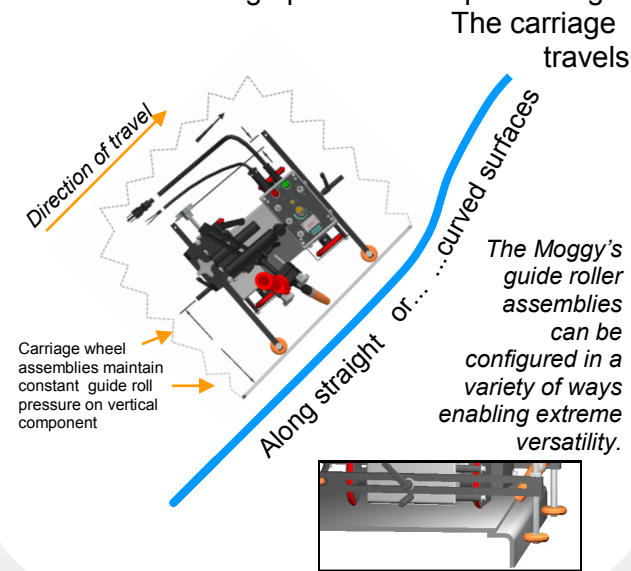

Accessories available

Model GK-194-O-330- Radial Oscillator complete with bracketry for mounting on Gullco Moggy Carriage.

Model GM-01-064- Adjustable Guide Roller Assembly enables joint tracking where the vertical member is lower/higher than set height of guide roller wheels.

Model GM-01-065- Cutting Torch Holder Assembly enables automated torch cutting operations.

GM-01-070- Dual Gun Holder Assembly enables the use of two independently positioned welding guns with two wire feed signals simultaneously activated.

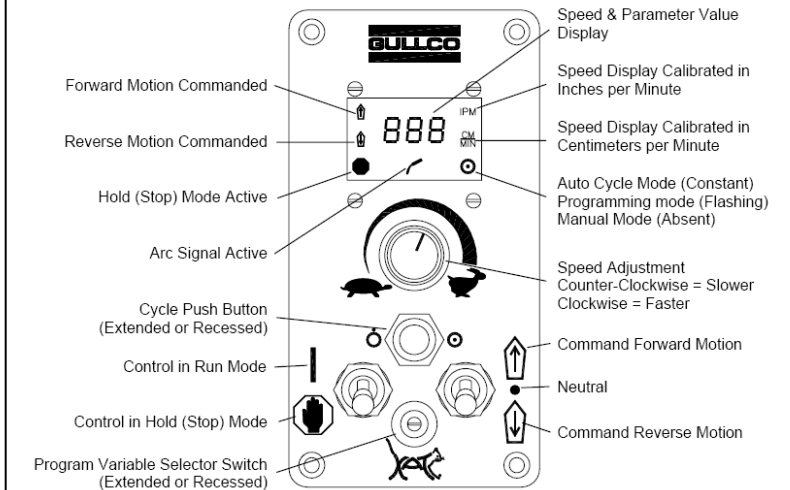

SPECIFICATIONS

STANDARD	MAGNETIC
Speed Range 6 to 115 in/min (15.2 to 292.2 cm/min)	3 to 57 in/min (7-146 cm/min)
Dimensions:	
Length	16 in. (406.4 mm)
Width.....	12 in. (311.1 mm)
Height	11 in. (279.4 mm)
Weight	30 lbs. (13.6kgs)

Also available as a SUBMERGED ARC MOGGY



SAM Submerged Arc Carriage... shown set at 45° for beam welding application.



Visit us at
WWW.GULLCO.COM

