



800 AMP ELECTRONIC ARC HEIGHT SENSOR (E.A.H.S.)



GK-203-800-* (* INDICATES VOLTAGE REFERENCE)

PARTS LIST & OPERATING INSTRUCTIONS

Website: www.gullco.com

Distributed by:

GULLCO INTERNATIONAL LIMITED – CANADA

Phone: 905-953-4140 Fax: 905-953-4138 e-mail: sales@gullco.com

GULLCO INTERNATIONAL INC. – U.S.A.

Phone: 440-439-8333 Fax: 440-439-3634 e-mail: ussales@gullco.com

GULLCO INTERNATIONAL [U.K.] LIMITED - EUROPE

Phone: +44 1257-253579 Fax: +44 1257-254629 e-mail: sales@gullco.co.uk

GULLCO INTERNATIONAL PTY LIMITED - AUSTRALIA

Phone: 61 (0) 7 5439-0701 Fax: 61 (0) 7 5439-0704 e-mail: ausales@gullco.com

GULLCO INTERNATIONAL LIMITED – INDIA

Phone: 91-20-65260382 Fax: 91-20-26836656 e-mail: India.io@gullco.com

GULLCO INTERNATIONAL SHANGHAI – LIMITED

Phone: +8621-50460341 Fax: +8621-50463554 e-mail: gsuntech@sh163.net

SAFETY INSTRUCTIONS

Although the Electronic Arc Height Sensor (E.A.H.S.) is manufactured for safe and dependable operation, it is impossible to anticipate those combinations of circumstances, which could result in an accident. An operator of this equipment is cautioned to always practice "**Safety First**" during each phase of operation, setup and maintenance.

Read and understand the whole operating instructions before operating or performing service of this equipment. Become familiar with the machine operation, applications and limitations. Keep the operating instructions in a clean and readily available location.

This equipment is normally used to automate / semi-automate welding processes. These processes usually have any combination of the following; bright and hot arcs, flying sparks, fumes, ultraviolet and infrared radiated energy, hot work-pieces, compressed gases, etc. The onus is on the operator of this equipment to know, understand and follow all the safety precautions associated with the process being used.

A careless operator invites troubles, and failure to follow safety practices may cause serious injury or even death. Important safety precautions are given in the following:

Electrical Shock Prevention

- Do not use this equipment in damp or wet locations.
- Do not expose this equipment to rain.
- Never carry this equipment by the cables or pull the cables to disconnect from the receptacle.
- Keep all cables from heat, oil and sharp edges.
- Inspect all cables periodically and replace if damaged.
- Inspect the secureness of all cables periodically and repair if loose.
- Disconnect the power cord when not in use.
- Disconnect the power cord **positively** to prevent electrical shock before repair and service of the equipment.

Bodily Injury Prevention

- Do not wear loose clothing, jewellery and loose, long hair, which may get caught into automatic systems or moving parts.
- Do not operate this equipment if ill or drowsy from medication or fatigue.
- Always keep the Electronic Arc Height Sensor (E.A.H.S.) clean and in good working order.
- Report any unsafe condition for immediate correction.

ALL THE SAFE PRACTICES AND PRECAUTIONS MAY NOT BE GIVEN IN WRITING. SOME ARE BASED ON COMMON SENSE, BUT OTHERS MAY REQUIRE TECHNICAL BACKGROUND TO EXPLAIN.

SAFETY INSTRUCTIONS

The following cautionary/warning label is attached to each Electronic Arc Height Sensor (E.A.H.S.):-

The below label pictorially represents the following:

“Warning:-

*Read the manual before turning the unit on and before performing service.
Also, positively disconnect the unit from all power supplies before servicing!”*

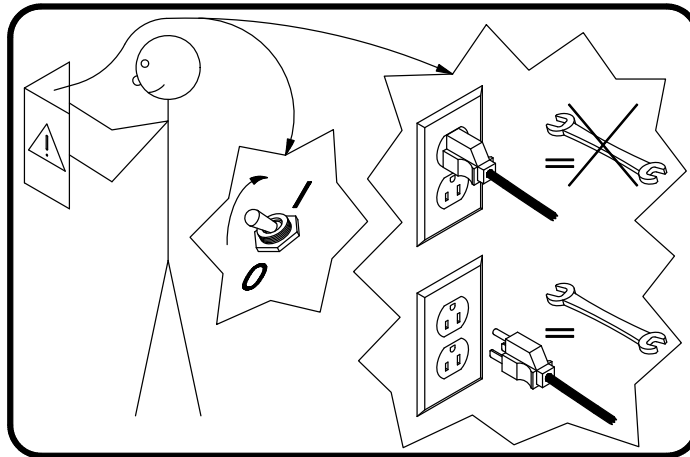

READ THIS BEFORE OPERATING THE E.A.H.S. UNIT

Always turn the main power off before connecting/disconnecting the cables to/from the Remote Control Pendant, slide and control box. Failure to comply may result in control damage.



The control must not be continually started and stopped by the removal and re-applying of power.



Allow ten (10) seconds after the removal of power before re-applying the power to the control.

Ensure that an adequate and well-maintained weld return path is provided with good electrical contact. Failure to do so may result in the welding current passing through the equipment and damaging the wiring and electrical components.

ELECTRICAL CONNECTION

WARNING! Before connecting the E.A.H.S. to a power source (receptacle, outlet, etc.,) be sure that the voltage supplied is the same as that specified on the product label. If in doubt, DO NOT PLUG IN THE E.A.H.S. Copies of the possible product labels are shown below:

		NEWMARKET, CANADA APPLEY BRIDGE, ENGLAND CLEVELAND, OH., U.S.A. PUNE, INDIA QUEENSLAND, AUSTRALIA		
www.gulco.com				
MODEL				
SERIAL #				
SUPPLY		42 V ~	50/60 Hz.	1 Ø
WATTS 100	YEAR 2010			
FUSE 2.5 SLOW BLOW		CE		

		NEWMARKET, CANADA APPLEY BRIDGE, ENGLAND CLEVELAND, OH., U.S.A. PUNE, INDIA QUEENSLAND, AUSTRALIA		
www.gulco.com				
MODEL				
SERIAL #				
SUPPLY		115 V ~	50/60 Hz.	1 Ø
WATTS 100	YEAR 2010			
FUSE 1.25 SLOW BLOW		CE		

		NEWMARKET, CANADA APPLEY BRIDGE, ENGLAND CLEVELAND, OH., U.S.A. PUNE, INDIA QUEENSLAND, AUSTRALIA		
www.gulco.com				
MODEL				
SERIAL #				
SUPPLY		230 V ~	50/60 Hz.	1 Ø
WATTS 100	YEAR 2010			
FUSE 0.5 SLOW BLOW		CE		

As the colours of the wires in the mains lead of this equipment may not correspond with the coloured markings identifying the terminals in your plug, proceed as follows:

- The Green & Yellow or Green wire must be connected to the terminal in the plug which is allocated for "Earth" / "Ground".
- The Blue or White wire must be connected to the terminal that is allocated for "Neutral".
- The Brown or Black wire must be connected to the terminal that is allocated for "Live".

230V Equipment must be installed in accordance with CEC, NEC or other applicable electrical code.

WARNING! Ensure proper AC earth grounding of the Gullco E.A.H.S. and all auxiliary equipment (where applicable), before applying power. Failure to do so may invalidate the Gullco Warranty.

Warranty will be void if genuine Gullco replacement parts are not used.

ELECTRONIC ARC HEIGHT SENSOR (E.A.H.S.)

This manual covers the operating instructions of the following Electronic Arc Height Sensor (E.A.H.S.):- GK-203-800-* (* indicates input voltage, A = 42V, B = 115V, C = 230V)

GENERAL DESCRIPTION

The Model GK-203-800 is a standalone unit meaning it does not interface with the customer's wire feeder. The arc activation trigger signal of the customer's welding equipment that is used to start/stop the welding process must come from a separate piece of equipment, i.e. customer supplied control or other Gullco equipment. This advanced Electric Arc Height Sensor package uses Gullco's sophisticated, yet easy to use, E.A.H.S. remote pendant control, in conjunction with a heavy duty 4" linear slide assembly and current sensing control box, to provide precision arc height control during the welding process.

The Gullco linear slide is compact, light weight, yet durable, linear motion device with high torque, high resolution and low vibration stepper motor. The slide imparts a linear motion to the welding gun. The low voltage E.A.H.S. control provides user friendly functions while minimizing set-up and welding down time. The Gullco E.A.H.S. system offers the following functions and features:

- Lightweight and durable components to reduce operator fatigue.
- The 4" standard heavy duty slide features engraved top, bottom and center marks for quick slide position reference to aid setup.
- Standard 25 feet of remote pendant control cable means the current sensor main control box can be kept away from the work area reducing trip hazards; an additional 25ft extension is available.
- Easy setup and torch height calibration (teach mode).
- Sensor control box design allows the operator to use their standard existing welding cables without any cutting or splicing that would be needed for a shunt type sensor.
- Extremely accurate arc detection within 2% to 97% of the nominal amp range.
- Slide travel speed factory set at 10 IPM [25.4cm/min], programmable range of 3 IPM [7.6cm/min] to 17 IPM [43.2cm/min].
- Easy to use remote pendant interface.
- Coarse and fine slide adjustment.
- Built in fault code diagnostics.

These features enable precise control over the torch height, generating accurate and repetitive high quality results.

The E.A.H.S. sensor main control box is available in three line voltage inputs; 42, 115 and 230 VAC, single phase, 50/60 Hz.

Supplied mounting bracketry for the slide allows for easy pivoting while the carriage block mounting plate allows for additional drilling and/or tapping, thus allowing the customer to fabricate it to their application.

INTENDED / FORESEEN USAGE

The Gullco Electronic Arc Height Sensor (E.A.H.S.) system is used throughout the world to automate and improve the quality and efficiency of the weld produced in automatic mechanized welding operations. This is achieved through minimizing weld defects such as poor penetration, incomplete fusion, overlap and undercut. Also, detrimental factors such as poor or awkward accessibility, operator fatigue, or inconsistent workmanship are eliminated. Required quality levels are consistently attained and productivity and profitability increased.

Welding guns are readily mounted on the linear slide. This equipment is intended to automatically control the torch height throughout the welding process. The longitudinal movement can be obtained from either the work piece traveling whilst the linear remains stationary, or, by a travel carriage such as the Gullco "KAT"® carriage carrying the E.A.H.S. equipment down the length of the work piece, which is the norm. By combining welding gun height control with the precision controlled travel speed of the "KAT"® carriage high quality workmanship can be produced.

GK-203-800 E.A.H.S. SYSTEM COMPONENTS AND GENERAL ASSEMBLY

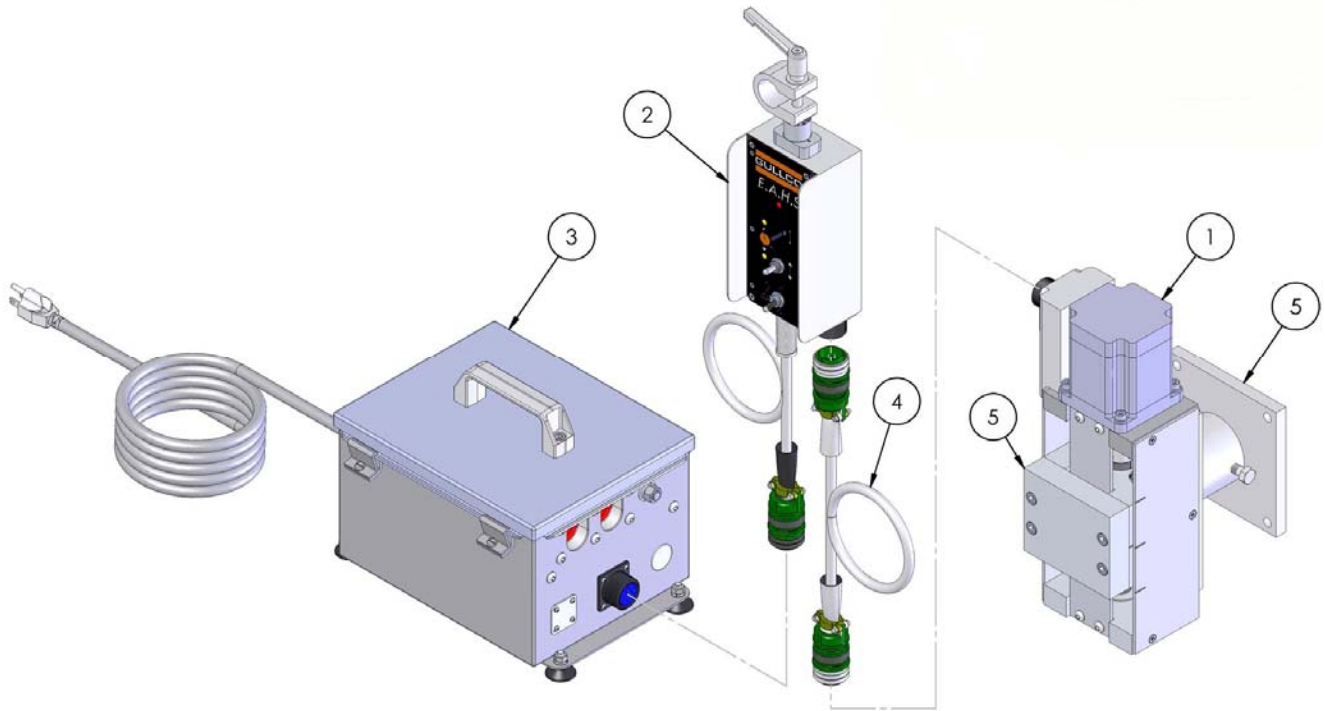

ITEM	PART NO.	DESCRIPTION	QTY.
1	GK-203-007	HEAVY DUTY SLIDE ASSEMBLY	1
2	GK-203-002	E.A.H.S. REMOTE PENDANT	1
3	GK-203-014-A	800 AMP CONTROL BOX ASSEMBLY 42V INPUT	1
	GK-203-014-B	800 AMP CONTROL BOX ASSEMBLY 115V INPUT	1
	GK-203-014-C	800 AMP CONTROL BOX ASSEMBLY 230V INPUT	1
4	GK-201-125	HEAD CABLE ASSEMBLY	1
5	GK-203-093	HD SLIDE MOUNTING HARDWARE	1

SETUP

Before powering up the E.A.H.S. make sure all components and cables are properly connected. There are three (3) major components to the E.A.H.S. system; the sensor control box, the remote pendant and the 4" linear slide. In order for the E.A.H.S. system to operate, the welding ground cable must be routed through the sensor control box. The direction of current flow or polarity is important or the E.A.H.S. will not be able detect current thus not allowing it to track the arc height automatically. To open the sensor control box loosen the lid clamping screws until the lid can be opened. Inside the control box there are two (2) cable dust covers, two (2) cable clamps and the current sensor. To install the welding ground cable open both dust covers and remove the wing screws on both cable clamps. Remove small Phillips screw from the current sensor and open it. Place all welding ground cable inside, shown below. Then close the current sensor reinstalling the Phillips screw and tightening the cable clamps. Close the dust covers and the lid, then tighten the lid clamp screws.

Electrode positive setup ("+" torch)

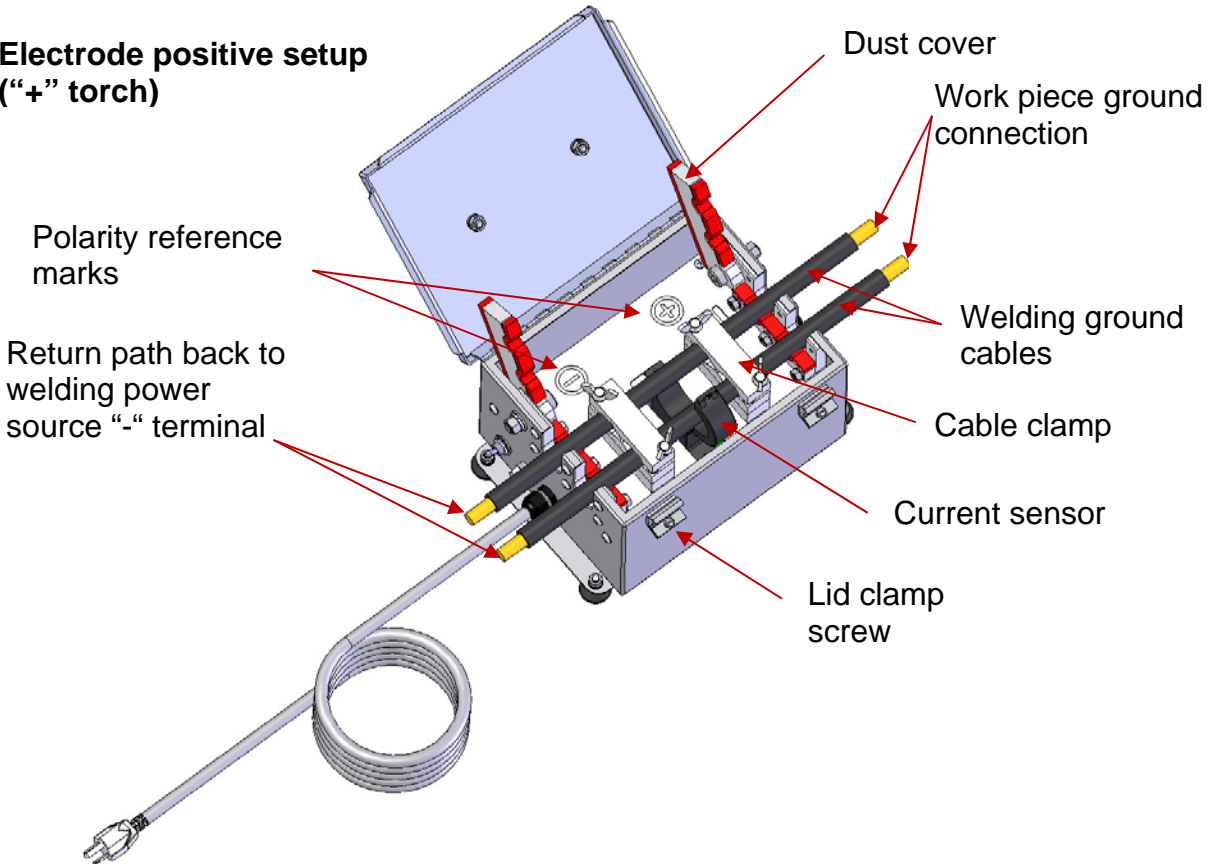

For electrode negative setup ("-" torch), flip the orientation of the welding ground in relation the control box, the "+" reference will face welding power source while the "-" reference will face the work piece.

Note: Care should be taken to ensure that no foreign debris enters the main control box, periodically check the condition of the foam gaskets and replace any that are damaged or defective.

The E.A.H.S. system comes standard with Gullco's heavy duty 4" linear slide with a heavy duty pivot mounting assembly which will accommodate a wide range of mounting positions. The carriage block mounting plate can be drilled and/or tapped, thus allowing the customer to fabricate it to their application.

The 6'-6" long slide control cable must be connected to the remote pendant and to the slide before the E.A.H.S. is powered up, and can only be removed when the power is OFF. Not doing so could result in control damage.

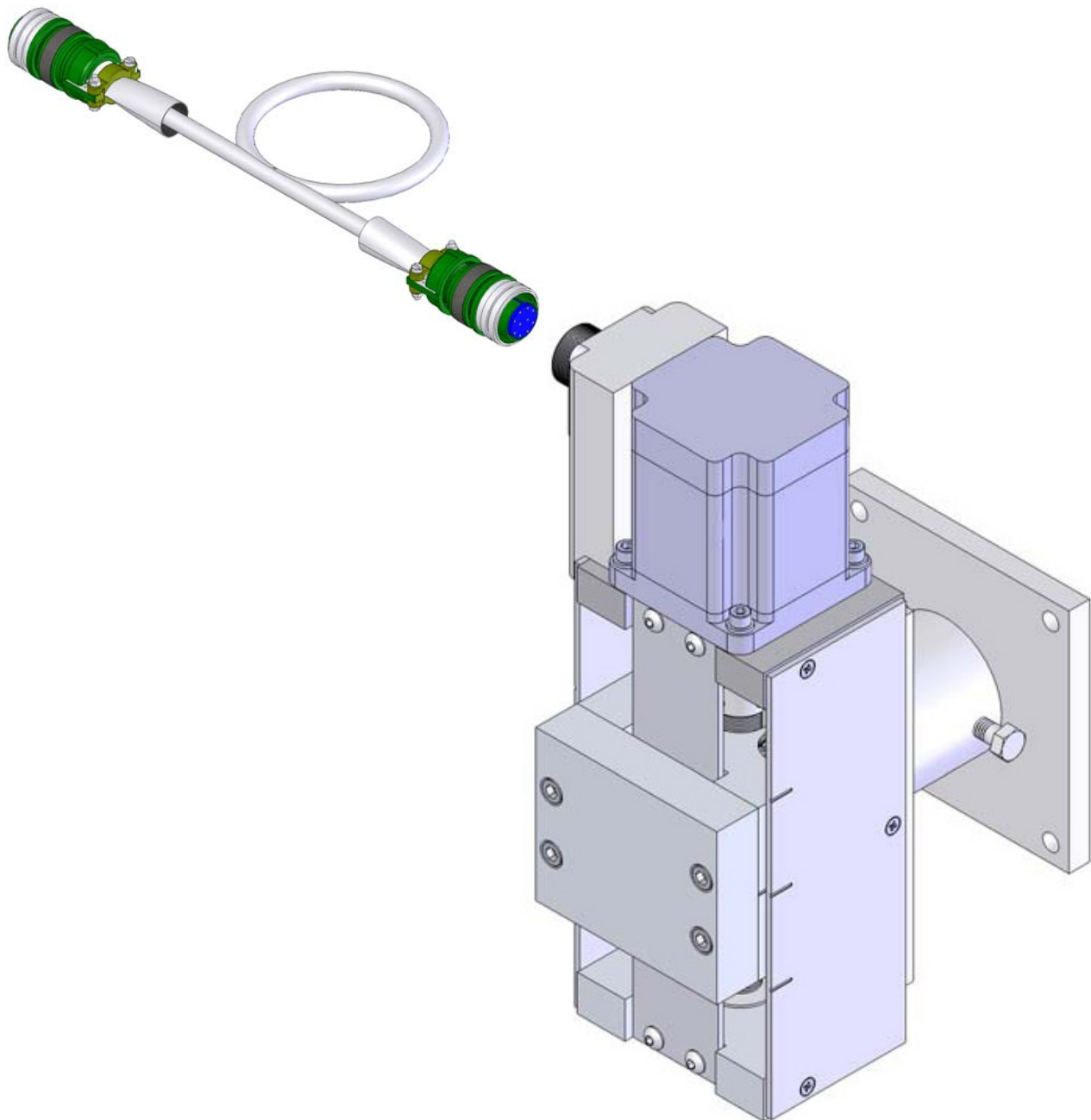

Operation

The Power On/Off switch (located on the back of the main control box) is used to disconnect the power to the rest of the control circuitry.

I = On, O = Off.

WARNING! Always turn the main power off before connecting/disconnecting the linear slide head cable to/from the remote pendant and the remote pendant from the control box. Failure to comply may result in control damage.

WARNING! The E.A.H.S. controls must not be continually started and stopped by the removal and reapplying of power to the controls. Allow ten (10) seconds after the removal of power before reapplying the power to the equipment.

The fuse holder (located on the back of the sensor control box) allows accessibility to the main fuse by pushing the cap in towards the main body and twisting in a counter-clockwise direction.

The remote pendant connector (located on the front of main control box) is used to interface between the main control box and the remote pendant.

The 4" linear slide connector (located on the bottom end of the remote control pendant) can be connected to the linear slide (located on the top of the linear slide).

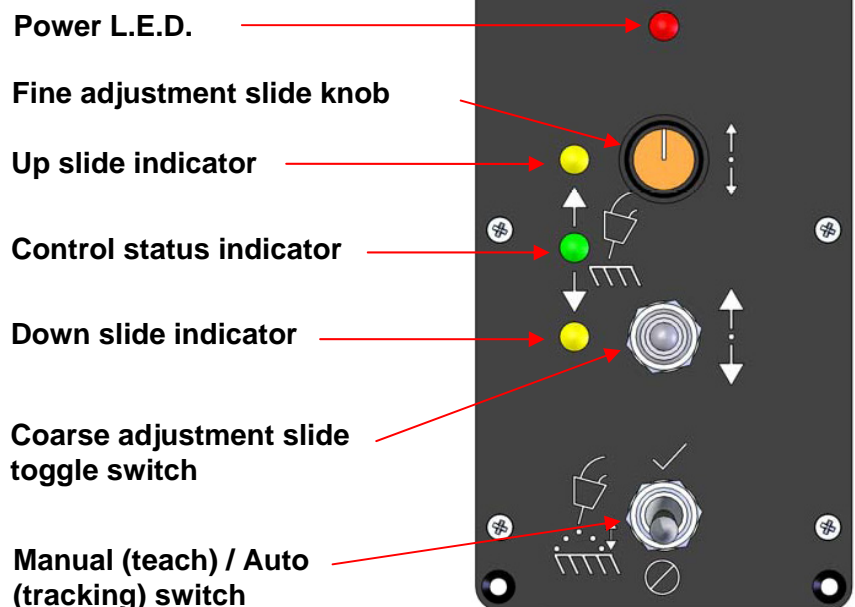

E.A.H.S. remote pendant control

A highly sophisticated, yet easy to use, micro-processor based control drives a high torque, high resolution, low vibration stepper motor located in the linear slide, allowing the height of the welding gun to be precisely controlled. The control interfaces with the linear slide through a removable head cable assembly and with the main control box through a fixed pendant control cable. By controlling the height of the welding torch, the quality and appearance of the weld can be tuned to perfection.



The E.A.H.S. works by measuring welding current, comparing it to a target value that has been taught by the operator and automatically adjusting the height of the welding gun to maintain the target welding current.

To teach the target welding current:

1. Place the Manual (Teach)/Auto (Tracking) toggle switch in the Manual (Teach) position ().
2. Perform a weld, adjusting the welding voltage, wire feed speed, travel speed and gun positioning until desired weld is achieved. The E.A.H.S. fine adjustment slide knob, and/or the coarse adjustment slide switch is used to set the desired tip to work distance.
3. While welding at the desired parameters, place the Manual (Teach)/Auto (Tracking) toggle switch in the Auto (Tracking) position (). The value of the welding current at this time is recorded as the new target value as indicated by a single beep from the control.
4. Adjustments can be made to the target value, by using either the fine adjustment slide knob, and/or the coarse adjustment slide switch during a weld the manual (Teach)/Auto (Tracking) toggle switch in the Auto (Tracking) position.

Once the target welding current has been taught, as described above, simply make sure that the Manual (Teach)/Auto (Tracking) toggle switch is in the Auto (Tracking) position prior to starting new welds, for the E.A.H.S. to use the same target value.

Fine adjustment slide knob: Provides fine slide adjustment. In manual mode each click is equal to 0.20" or 0.5mm. In auto mode it is equal to 3.2 amps when working in 0-800amp range.

Coarse adjustment slide toggle switch: Provides coarse slide adjustment. In manual and auto mode holding to toggle switch in either direction results in a ramping slide speed up to 23 IPM [58.4 cm/min].

Power L.E.D.: Whenever the E.A.H.S. is powered "ON" the red L.E.D. will be on solid. When control displays an error code it will flash once per second until the error code is cleared, see page 13 for error codes.

Up slide indicator L.E.D.: This yellow L.E.D. is used to display the tracking movement of the slide in the up direction in Auto mode. Any time the slide automatically adjusts the height of the torch in this direction the L.E.D. will come on. This L.E.D. is also used for displaying error and warning codes, see page 13 for error and warning codes.

Control status indicator L.E.D.: This three (3) colour L.E.D. (Red, Yellow Green) indicates the tracking status of the control when in Auto mode. Red means that the control is in Auto mode but detects no weld current. Yellow means the control is calibrating for tracking, accompanied by a one (1) sec beep from the remote pendant. Green means the control is in Auto mode and detects current and is automatically tracking the arc height. This L.E.D. is also used for displaying error and warning codes, see page 13 for error and warning codes.

Down slide indicator L.E.D.: This yellow L.E.D. is used to display the tracking movement of the slide in the down direction in Auto mode. Any time the slide automatically adjusts the height of the torch in this direction the L.E.D. will come on. This L.E.D. is also used for displaying error and warning codes, see page 13 for error and warning codes.

Setting the Dip Switches for control calibration

Located on the back of keypad control board (inside the remote pendant control) there are three (3) blocks of dip switches “DS71, DS72, and DS73”. All switches come from the factory in the positions shown and under normal circumstances will not need adjustment, see below.



WARNING! Always turn the main power off before making any changes to the dip switch positions on the remote pendant control. Failure to comply may result in control damage.

DS71 is used to calibrate the slide speed or slide tracking speed. It is the speed at which the slide moves as it compensates for changes in torch height while in Auto mode. It is factory set at 10 IPM [25.4 cm/min]. It can be increased or decreased in 1 IPM [2.54 cm/min] increments between 3 IPM [7.62 cm/min] to 17 IPM [43.18 cm/min]. The factory default of 10 IPM [25.4 cm/min] is recommended for most applications. Where the carriage speed is high and large undulations in the work piece exist then increasing the slide speed may yield better results. The following table shows how set the switches for different speeds. Switches 1 to 4 factory set in the up (OFF) position.

Slide speed IPM [cm/min]	SWITCH 1	SWITCH 2	SWITCH 3	SWITCH 4
3 [7.62]	down	Down	down	down
4 [10.16]	up	Down	down	down
5 [12.5]	down	Up	down	down
6 [15.24]	up	Up	down	down
7 [17.78]	down	Down	up	down
8 [20.32]	up	Down	up	down
9 [22.86]	down	Up	up	down
10 [25.4] factory set	up	Up	up	up
11 [27.94]	down	Up	Up	up
12 [30.48]	up	Down	Up	up
13 [33.02]	down	Down	Up	up
14 [35.56]	up	Up	Down	up
15 [38.1]	down	Up	Down	up
16 [40.64]	up	Down	Down	up
17 [43.18]	down	Down	Down	up

DS72 Switch 1 and 2 is used to calibrate the control to the type of slide. The heavy duty slide (GK-203-007) is factory set. The 4" standard slide (GK-203-001) is optional. See below table. Note: when changing slides, Dip switch S42 on the motor control board has to be set as well.

Linear Slide Type	SWITCH 1	SWITCH 2
STD SLIDE GK-203-001 (optional)	Up	Up
HD 4" SLIDE GK-203-007 (factory set)	Down	Up
N/A	Up	Down
N/A	Down	Down

DS72 Switch 3 is used to set the top and bottom orientation of the slide. Depending on how the linear slide is mounted relative to the control, the top & bottom locations and manual jog (steering) may be opposite to that expected. This field allows virtual orientation reversal of the linear slide. The choices available are either "top/bottom" or "bottom/top". The control will also reassign limit switch input logic to suit. See below table.

"top" and "bottom" Orientation	SWITCH 3
"top/bottom" (factory set)	up
"bottom/top"	down

DS72 Switch 4 is non-functional and for future use.

DS73 Switch 1 to 4 are non-functional and for future use.

Motor Board Dip Switch (S42) Settings

Dip Switch S42, is located on the back of the motor control board inside the remote pendant. This switch is used to calibrate the motor board to the type of slide. The heavy duty slide (GK-203-007) is factory set. The 4" standard slide (GK-203-001) is optional. See below table. Note: when changing slides, Dip switch DS72 on the back of keypad control board (inside the remote pendant control) has to be set as well.

SWITCH 1	SWITCH 2	SETTINGS
Off	Off	Heavy Duty slide (GK-203-007)
On	Off	Standard slide (GK-203-001)
Off	On	Future use
On	On	Future use

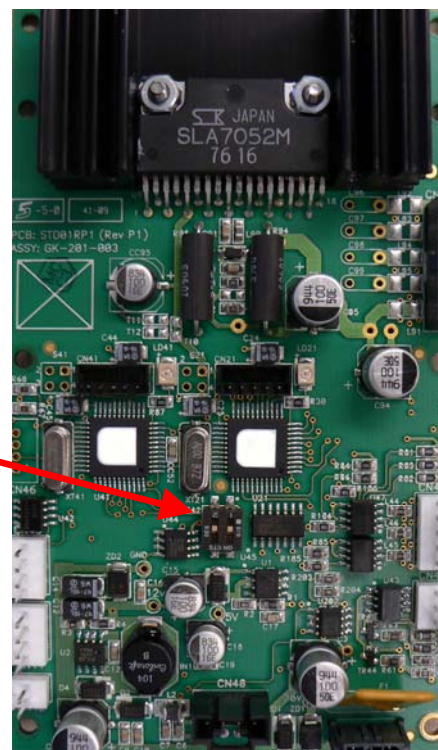

Error Codes and Audible Warnings

Whenever the E.A.H.S. system encounters a fault and/or a condition outside of the normal operating parameters it will display an error code and/or sound an audible warning. Use the following tables and descriptions for further explanation.

If the E.A.H.S. system encounters a problem that results in an error code, the system will shut down (unable to automatically track arc height) and will display the code as follows. The red power L.E.D. will flash once per second (1 Hz) until the error code is cleared by resolving the cause of the problem. Depending on the type of error the flashing red L.E.D. may be accompanied by an audible beeping. Error codes are then read by interpreting the displayed sequence of the three (3) yellow L.E.D.'s, they are read from top to bottom (see below).

YELLOW L.E.D.'s	ER 1	ER 2	ER 3	ER 4	ER 5	ER 6	ER 7
TOP	off	off	off	on	on	on	on
MIDDLE	off	on	on	off	off	on	on
BOTTOM	on	off	on	off	on	off	on

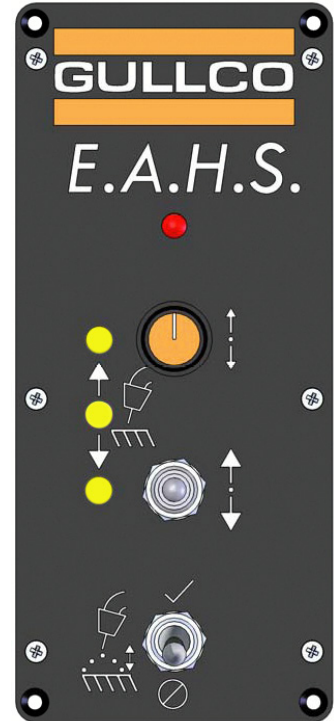

ER 1, Main Stepper Communication error: communication between the main stepper control microcontroller and the E.A.H.S. is malfunctioning. Consult your Gullco representative.

ER 2, Slave Stepper Communication error: communication between the slave stepper control microcontroller and the E.A.H.S. is malfunctioning. Consult your Gullco representative.

ER 3, Remote pendant keypad #690 Communication error: communication between the remote pendant keypad #690 control microcontroller and the E.A.H.S. is malfunctioning. Consult your Gullco representative.

ER 4, Current Sensor board Filter #690 Communication error: communication between the current sensor control microcontroller and the E.A.H.S. is malfunctioning. Consult your Gullco representative.

ER 5, Remote pendant keypad #6627 Communication error: communication between the remote pendant control #6627 microcontroller and the E.A.H.S. is malfunctioning. Consult your Gullco representative.

ER 6, Stepper Board over temperature error: the temperature of the driver on the stepper board, located inside the remote pendant, has exceeded 96°C or 205°F. The E.A.H.S. must be powered down and allowed cool for a short period of time in order to reset this code.

Under normal circumstances overheating should not occur but if the remote pendant was resting on a pre-heated work piece for a long period of time for example, then it will too be pre-heated. As a precaution the remote pendant should not be allowed to come into contact with hot material (above 96°C/205°F) for extended periods of time.

ER 7, Limit switches error: the E.A.H.S. has detected a fault in the limit switch communication that could be a result of a damaged control cable between the slide and the pendant. Re-check all relevant connections to resolve the issue.

The E.A.H.S. system will sound audible warnings to alert the operator of a change in status or a possible problem.

- 1) During calibration when the switch is moved from Manual to Auto while welding current is detected or when the switch is in the Auto position and a arc is struck, the remote pendant will sound one (1) beep for one (1) second duration. This will indicate to the operator that the E.A.H.S. is now in tracking mode.
- 2) While the E.A.H.S. system is tracking (current detected) in Auto mode and a limit switch is triggered (top or bottom of slide) the remote pendant will sound three (3) beeps per second and also flash the corresponding slide indicator L.E.D. on the remote pendant control. This is to let the operator know that the slide has reached its maximum travel in that direction. If this occurs the E.A.H.S. will continue to try to track in Auto mode with the three (3) beeps per second alarm continuing until the operator makes adjustments to the bracketry that the slide is mounted to, or shuts down the process and adjusting the bracketry to permit more travel in the desired direction. Note: even though the E.A.H.S. will remain tracking during this alarm it will only be able to make height adjustments in one direction until it moves off of the limit switch, this could result in reduced control and quality of the welding process.
- 3) While welding & in Manual mode if the operator decides to switch to Auto mode and the E.A.H.S. system detects the conditions stated in the above (point 2) the process will be treated the same.
- 4) While the E.A.H.S. system is tracking (current detected) in Auto mode if the operator makes adjustments to the arc height by either the fine adjustment slide knob or coarse adjustment slide toggle switch, if the resulting target current would go beyond the 20 amp (low limit) or 776 amp (high limit) the control will not let the operator make any further adjustments out of the range. This is done by limiting the slide movement. The control will sound a single beep each time the operator attempts to move the slide beyond these limits with the knob or the toggle switch.
- 5) In the case that the Auto cycle is initiated during welding and the E.A.H.S. detects a current above 792 amps (example 850 amps) the control will continually beep and the target current will be set at the maximum target of 776

Troubleshooting

E.A.H.S. is not working.

Possible cause(s): no power going to the E.A.H.S.

Possible solution(s): first check that the power toggle switch is “ON”, the red L.E.D. on the remote pendant should be on. If not verify that the unit is plugged into the correct supply voltage, then check the fuse and all cables are plugged in.

E.A.H.S. is working, but will not calibrate or track in auto mode.

Possible cause(s): check polarity of welding ground cable passing through the current sensor.

Possible solution(s): verify if the welding process is electrode positive or negative. If the process is electro positive (positive welding torch) the welding ground cable passes through the current sensor with “-ve” symbol on the control box facing the welding power source and “+ve” facing the work piece. See page 7 for details

The slide does not respond to height adjustment.

Possible cause(s): Limit switch on slide is activated, faulty slide control cable, cable not connected properly. E.A.H.S. is either tracking at 20 amps (bottom limit) or 776 amps (top limit), in both cases the control automatically restricts the slide travel to prevent it going below 20 amps or above 776 amps.

Possible solution(s): Orient the slide so there is sufficient up and down travel during welding without activating the limit switches. Verify that welding parameters are between 20 and 776 amps.

The slide moves in the opposite direction while in Manual mode to what is expected.

Possible cause(s): Depending on the orientation of the linear slide it may be necessary to flip the position of **DS72 switch 3** to correct the problem.

Possible solution(s): flip the position of **DS72 switch 3**, see page 12 for details.

Continued on next page

During tracking in auto mode the E.A.H.S. system unexpectedly goes out of tracking.

Possible cause(s): An unstable arc can momentarily cause a zero current condition which is less than 20 amps causing the E.A.H.S. to stop tracking. Once the arc becomes stable again it will recalibrate and track.

Possible solution(s): Verify welding parameters and that there is no wire feed issues (drive wheel slippage) that would cause an unstable arc.

DETAILED PARTS BREAKDOWN

GK-203-002: E.A.H.S. REMOTE PENDANT

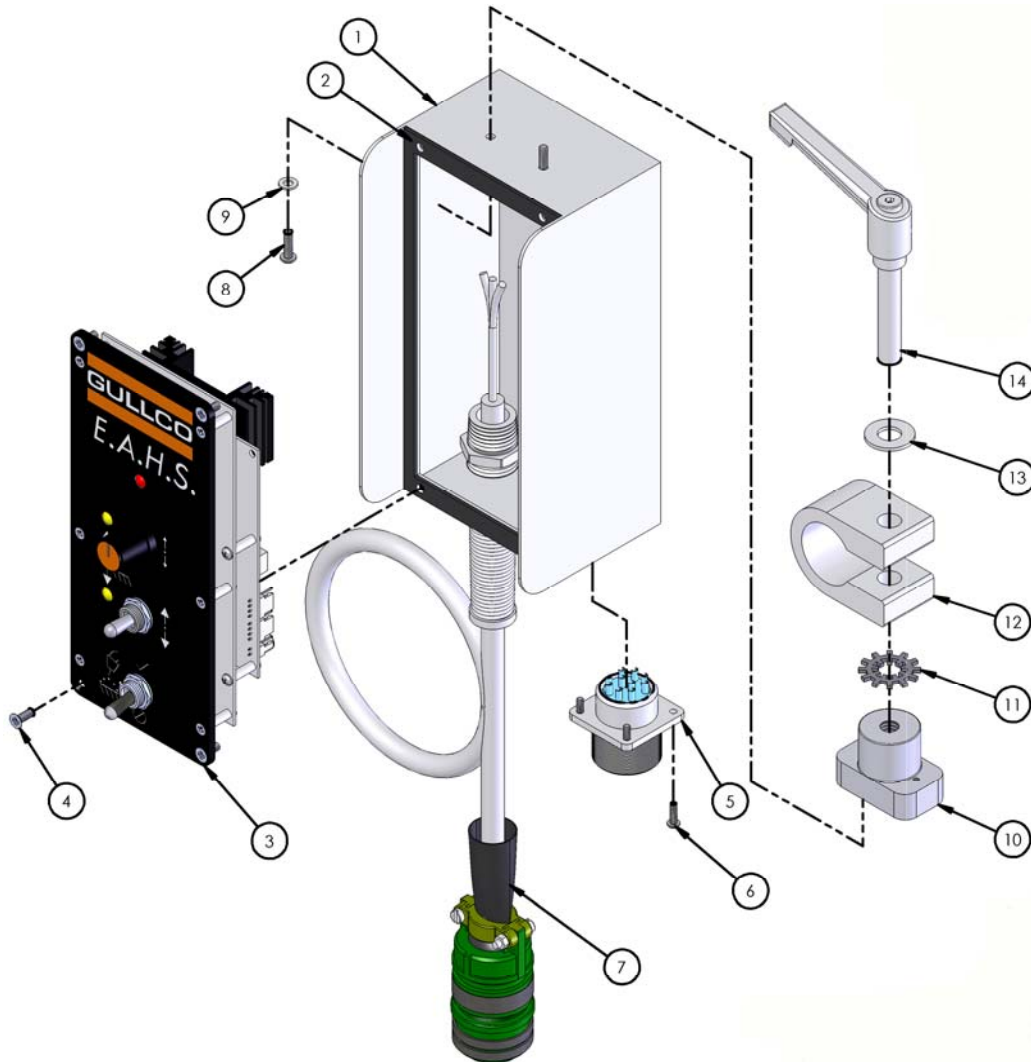

ITEM	PART NO.	DESCRIPTION	QTY.
1	GK-203-005	E.A.H.S. CONTROL BOX	1
2	GK-203-045	E.A.H.S. REMOTE PENDANT GASKET	1
3	GK-203-010	REMOTE PENDANT CONTROL	1
4	GK-141-002	#6-32UNC x 3/8 FHMS	4
5	GK-201-030	OSCILLATOR HEAD RECEPTICAL HARNESS ASSEMBLY	1
6	GK-112-056	#4-40UNC x 3/8 RND HEAD SCREW	4
7	GK-203-004	E.A.H.S. PENDANT CABLE ASSEMBLY	1
8	GK-112-051	#6-32UNC x 1/2 RND HEAD SCREW	2
9	GK-111-059	WASHER #6 BOLT x 5/16 OD x 0.033	2
10	GK-190-161	SWIVEL MOUNTING BRACKET	1
11	GK-129-007	3/8 COMBINATION STAR WASHER	1
12	GK-166-183	1-1/8 SWIVEL CLAMP	1
13	GK-111-058	WASHER 3/8 BOLT x 13/16 OD x 1/16	1
14	GK-153-014	3/8-16UNC x 2.48" ADJUSTABLE HAND LEVER	1

GK-203-010: E.A.H.S. REMOTE PENDANT CONTROL

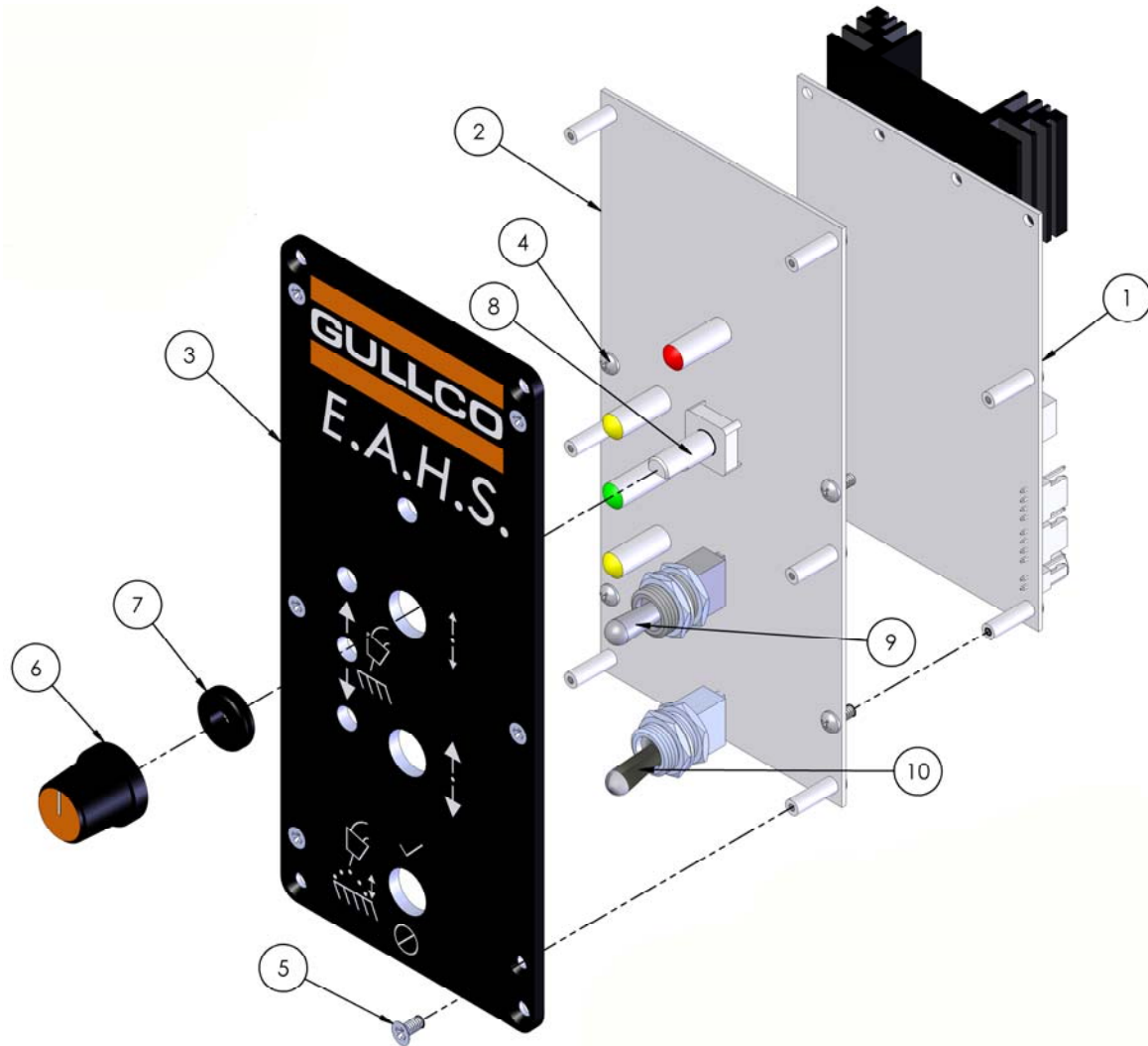

ITEM	PART NO.	DESCRIPTION	QTY.
1	GK-203-013	E.A.H.S. STEPPER DRIVER BOARD	1
2	GK-203-012	E.A.H.S. KEYPAD BOARD, INCLUDES ITEMS 8-10	1
3	GK-203-008	E.A.H.S. FACE PLATE	1
4	GK-112-060	#4-40UNC x 1/4 RND HEAD SCREW	4
5	GK-141-013	#4-40UNC x 1/4 FHMS	6
6	GK-191-P-097	SPEED SELECTOR KNOB	1
7	GK-151-004	GROMMET	1
8	GK-191-P-235	ROTARY ENCODER	1
9	GK-201-113	3 POSITION MOMENTARY SWITCH	1
10	GSP-2008	2 POSITION MAINTAINED SWITCH	1

GK-203-007: HEAVY DUTY SLIDE ASSEMBLY

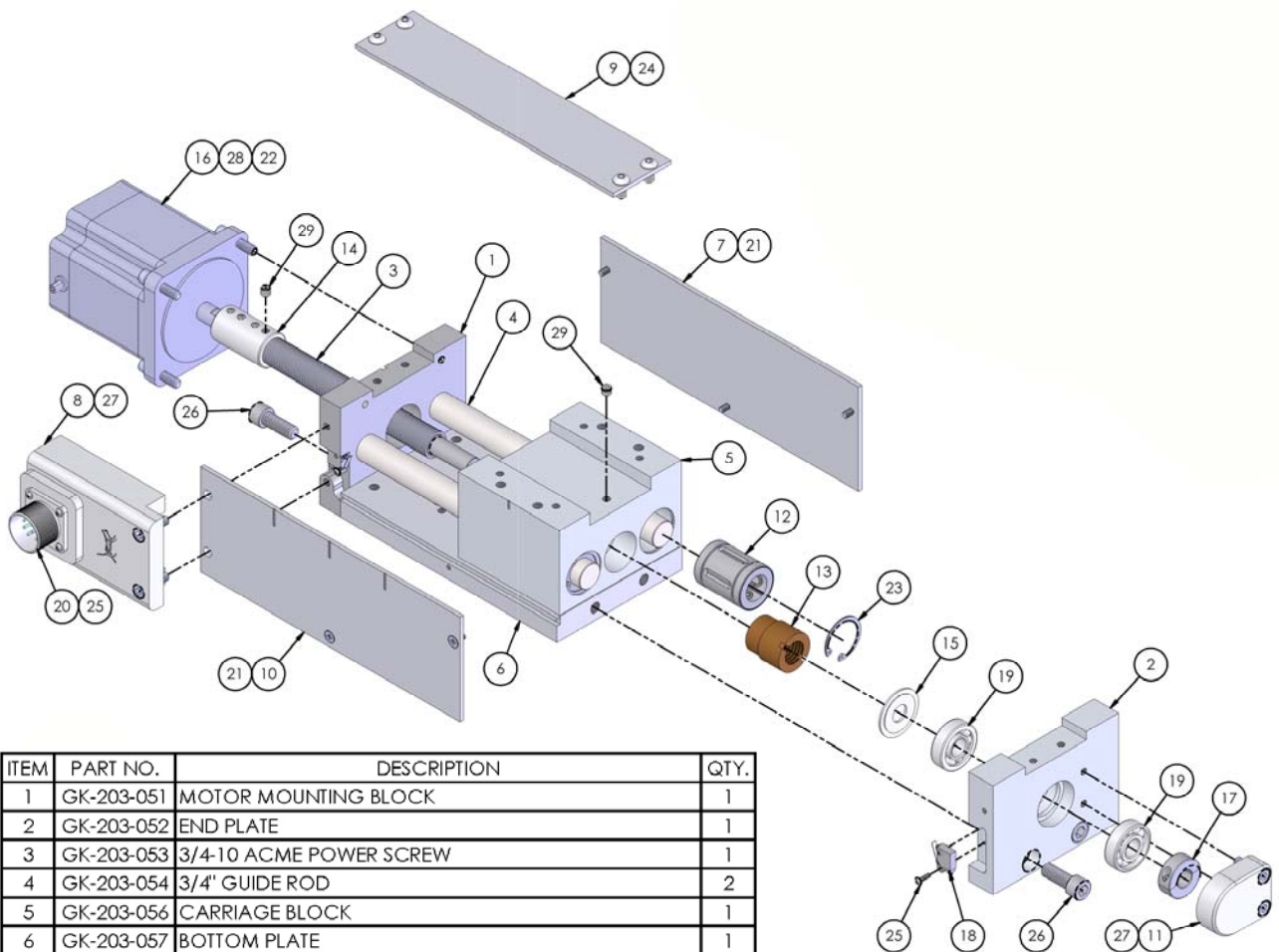

ITEM	PART NO.	DESCRIPTION	QTY.
1	GK-203-051	MOTOR MOUNTING BLOCK	1
2	GK-203-052	END PLATE	1
3	GK-203-053	3/4-10 ACME POWER SCREW	1
4	GK-203-054	3/4" GUIDE ROD	2
5	GK-203-056	CARRIAGE BLOCK	1
6	GK-203-057	BOTTOM PLATE	1
7	GK-203-058	SIDE COVER	1
8	GK-203-059	MOTOR COVER	1
9	GK-203-060	TOP COVER	1
10	GK-203-061	MOTOR SIDE COVER	1
11	GK-203-062	ACME SCREW CAP	1
12	GK-203-063	3/4" LINEAR BALL BUSHING BEARING	4
13	GK-203-064	3/4-10 ACME NUT	1
14	GK-203-065	MOTOR COUPLING	1
15	GK-203-066	BEARING SHIELD	1
16	GK-203-067	MOTOR ASSEMBLY	1
17	GK-203-068	1/2" SHAFT COLLAR	1
18	GK-203-069	LIMIT SWITCH HARNESS	1
19	GM-02-115	1/2" BORE ANGULAR CONTACT BEARING LJT1/2MB	2
20	GK-201-127	STEPPER MOTOR WIRE HARNESS ASSEMBLY	1
21	GK-141-010	#8-32UNC x 3/8 FHMS	5
22	GK-136-053	LOCK WASHER 1/4 BOLT	4
23	GK-119-077	1-1/4 INTERNAL RETAINING RING	4
24	GK-112-115	1/4-20UNC x 1/2 BHCS	4
25	GK-112-056	#4-40UNC x 3/8 RND HEAD SCREW	6
26	GK-107-070	3/8-16UNC x 1 SHCS	4
27	GK-107-054	1/4-20UNC x 3/4 SHCS	4
28	GK-107-052	1/4-20UNC x 1 SHCS	4
29	GK-106-082	1/4-28UNF x 1/4 SET SCREW	9

GK-203-003: E.A.H.S. CONTROL BOX

ITEM	PART NO.	DESCRIPTION	QTY.
1	GK-203-091	CAPACITOR WIRING HARNESS (NOT SHOWN)	1
2	GK-203-090	DISCHARGE RESISTOR WIRING HARNESS (NOT SHOWN)	1
3	GK-203-083-B	100VA TRANSFORMER 115V	1
	GK-203-083-C	100VA TRANSFORMER 230V	
4	GK-203-082	LID FOAM SEAL	2
5	GK-203-081	CABLE FOAM SEAL	4
6	GK-203-080	SENSOR BRACKET	1
7	GK-203-079	CABLE CLAMP - UPPER HALF	2
8	GK-203-078	CABLE CLAMP - LOWER HALF	2
9	GK-203-077	CABLE CLAMP BASE	2
10	GK-203-076	CABLE STRAIN MOUNTING PLATE	2
11	GK-203-075	CABLE STRAIN - UPPER HALF	2
12	GK-203-074	CABLE STRAIN - LOWER HALF	2
13	GK-203-073	LOWER PANEL	1
14	GK-203-072	UPPER PANEL	1
15	GK-203-071	CONTROL BOX	1
16	GK-203-042	LEVELLING FOOT	4
17	GK-203-035	UPPER PANEL BRACKET	2
18	GK-203-011	CURRENT SENSOR BOARD	1
19	GK-203-009	800AMP SENSOR	1
20	GK-203-006	CONTROL BOX CABLE ASSEMBLY	1
21	GP-200-021	HANDLE	1
22	GK-191-P-218	TRANSFORMER MOUNTING PAD	2
23	GK-191-P-150	RECEPTICAL COVER PLATE	1
24	GK-191-P-128	LINE CORD INTERFACE (NOT SHOWN)	1
25	GK-191-P-127	HIGH FREQUENCY CAPACITOR WIRING HARNESS (NOT SHOWN)	1
26	GK-191-P-105	TRANSFORMER MOUNTING PLATE	1
27	GK-191-P-063	CAPACITOR CLIP	1
28	GK-191-P-062	CAPACITOR	1
29	GK-191-P-056	ON/OFF SWITCH NUT	2
30	GK-191-P-050	ON/OFF NAME PLATE	1
31	GK-191-P-022	POWER ON/OFF SWITCH	1
32	GK-191-P-020	BRIDGE RECTIFIER	1
33	GK-171-032	POWER CORD 115V	1
	GK-171-032-X	POWER CORD WITHOUT PLUG (42V OR 230V)	
34	GK-165-134	FUSE HOLDER ASSEMBLY	1
35	GK-165-097	SLOW BLOW FUSE 1.25 AMP 115V	1
	GK-165-100	SLOW BLOW FUSE 1/2 AMP 230V	
36	GK-161-001	1/4-20 x 2' WING SCREW	4
37	GK-155-002	HOLE PLUG, 7/8"	1
38	GK-148-035	HEYCO LIQUID TIGHT STRIAIGHT-THRU FITTING	1
39	GK-136-063	LOCK WASHER 3/8 BOLT	2
40	GK-136-055	LOCK WASHER 5/16 BOLT	2
41	GK-136-053	LOCK WASHER 1/4 BOLT	4
42	GK-135-057	#10-32 LOCK NUT	6
43	GK-129-014	INTERNAL TOOTH LOCK WASHER	1
44	GK-112-128	1/4-20UNC x 3/4 BHCS	3
45	GK-112-122	1/4-20UNC x 1-1/4 BHCS	4
46	GK-112-120	1/4-20UNC x 3/8 BHCS	4
47	GK-112-115	1/4-20UNC x 1/2 BHCS	10
48	GK-112-068	#10-32UNF x 7/8 RND HEAD SCREW	2
49	GK-112-065	#10-32UNF x 3/8 RND HEAD SCREW	11
50	GK-112-060	#4-40UNC x 1/4 RND HEAD SCREW	16
51	GK-111-066	WASHER 1/4 BOLT x 1/2 OD x 0.033	10
52	GK-111-063	WASHER #10 BOLT x 1/2 OD x 0.052	7
53	GK-111-058	WASHER 3/8 BOLT x 13/16 OD x 1/16	2
54	GK-109-052	5/16-18UNC HEX NUT	2
55	GK-109-051	3/8-16UNC HEX NUT	2
56	GK-109-050	1/4-20UNC HEX NUT	10
57	GK-107-133	#10-32UNF x 2-1/2 SHCS	1
58	GK-107-080	#10-32UNF x 1 SHCS	1
59	GK-107-063	#10-32UNF x 1/2 SHCS	1
60	GK-107-056	#10-32UNF x 3/4 SHCS	1
61	GK-107-053	5/16-18UNC x 3/4 SHCS	2
62	GK-107-052	1/4-20UNC x 1 SHCS	4
63	GK-104-050	1/2 x 1 SHOULDER BOLT	2

GK-203-093: HD SLIDE MOUNTING HARDWARE

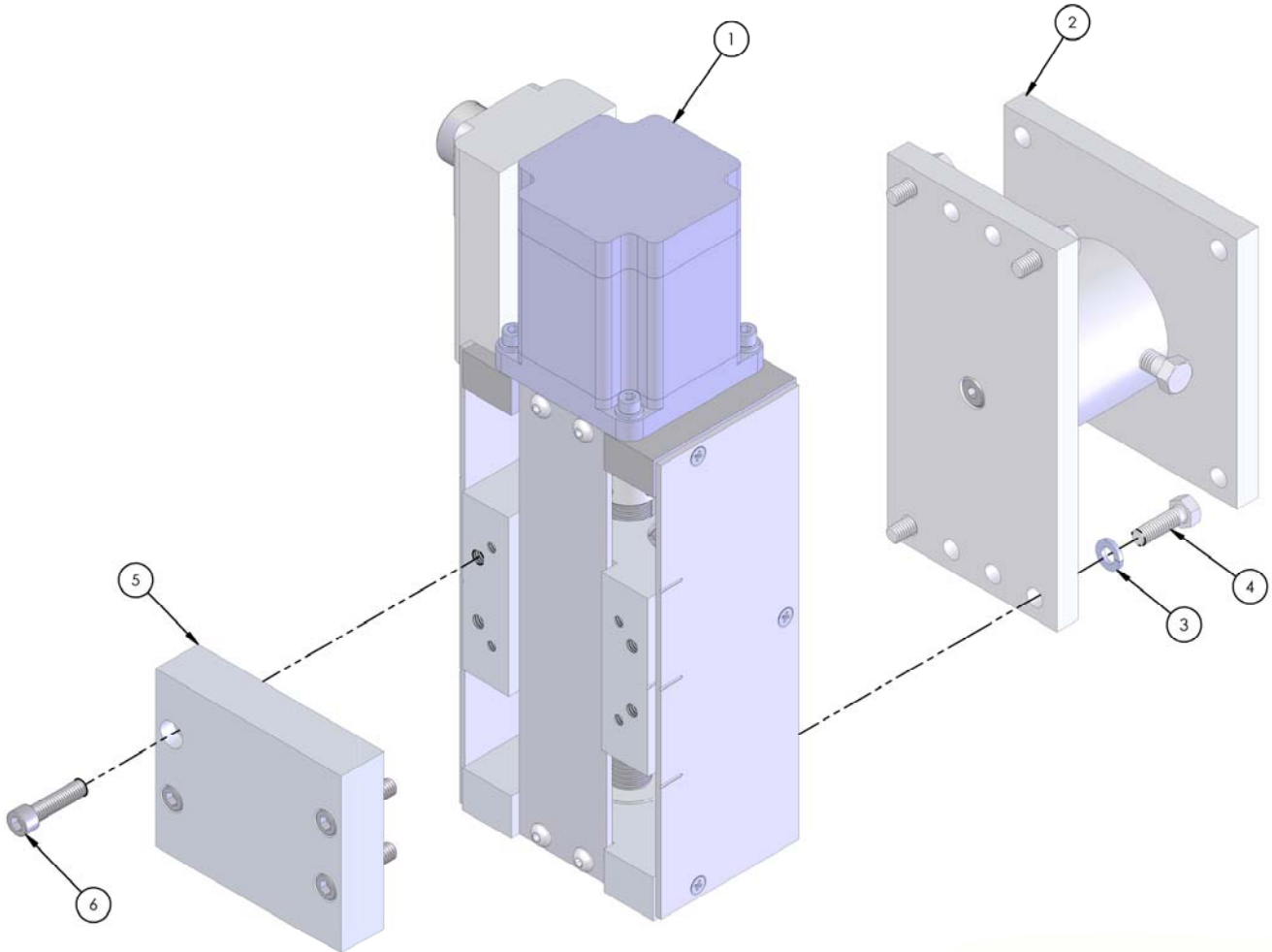

ITEM	PART NO.	DESCRIPTION	QTY.
1	GK-203-007	HD SLIDE (NOT INCLUDED)	1
2	WS-250-026	HEAVY DUTY PIVOT ASSEMBLY	1
3	GK-136-055	LOCK WASHER 5/16 BOLT	4
4	GK-108-075	5/16-18UNC x 1 HEX BOLT	4
5	GK-203-089	CARRIAGE BLOCK MOUNTING PLATE	1
6	GK-107-074	5/16-18UNC x 1-1/4 SHCS	4

OPTIONAL ACCESSORIES

GK-203-094: SAM HD SLIDE MOUNTING BRACKETS

These brackets allow the HD slide to be mounted to the Gullco SAM, GM-02-275 & GM-02-295.

Slide not included.

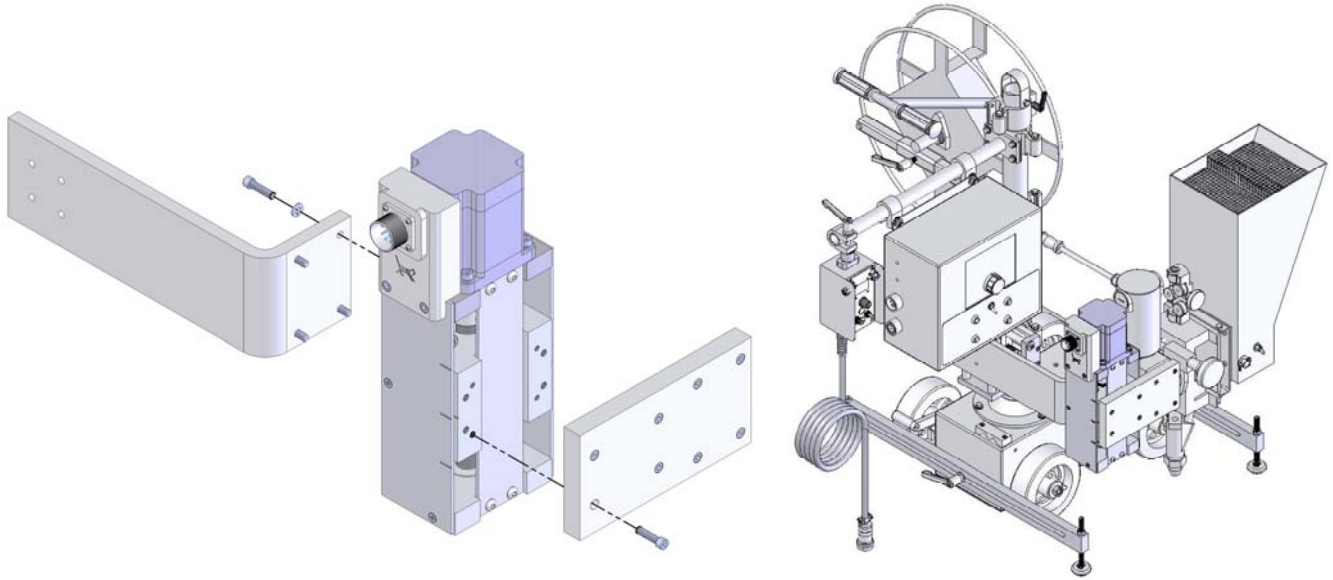

GK-203-092: REMOTE PENDANT EXTENSION 25 FT

This 25 foot extension will increase the total length of control cable between the control box and the remote pendant to 50 feet.



REVISIONS LIST

May, 2010

Overall

Creation of manual.

ADDITIONAL NOTES

Specifications and products are subject to change without notice.
Kat, Moggy, Sam & KATBAK are registered trademarks of Gullco International Enterprises Ltd.
Only use genuine/authorized replacement parts.

